

TEETH: 3 EFF
HOOK: 5°
SHEAR: 30° COMPRESSION
TIPS: PCD
PA: 158.4mm

NOTE: FLIP TOOL FOR OPPOSITE ROTATION

DWG: 1-02-3000200

A.K.A. #: N/A

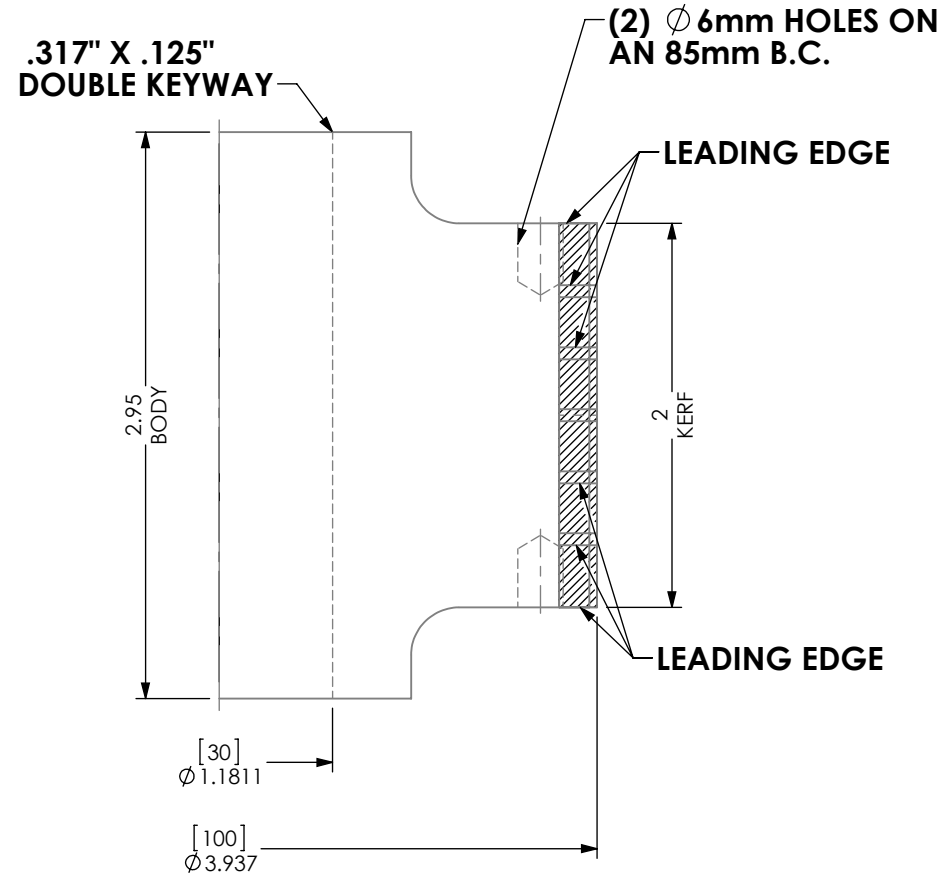

HALL MANUFACTURING DWG: 1-02-3000200

ATTN: _____ **DATE:** _____ **PO#:** _____

**CUSTOM TOOLING MUST HAVE CUSTOMER APPROVAL PRIOR TO THE START OF
 MANUFACTURING. PLEASE REVIEW THIS DRAWING FOR ACCURACY, INCLUDING
 ROTATION, AND FAX A SIGNED AND DATED COPY. PRODUCTION
 WILL BEGIN UPON RECEIPT OF APPROVED DRAWING.**

APPROVED BY: _____ **DATE:** _____

DATE:
8/15/14

DWN BY:
R.A.Y.



REV.	
+	SHEET 1 OF 2