

TEETH: 3 EFF.  
HOOK: 5°  
SHEAR: 30°  
TIPS: PCD  
PA: 101.25mm

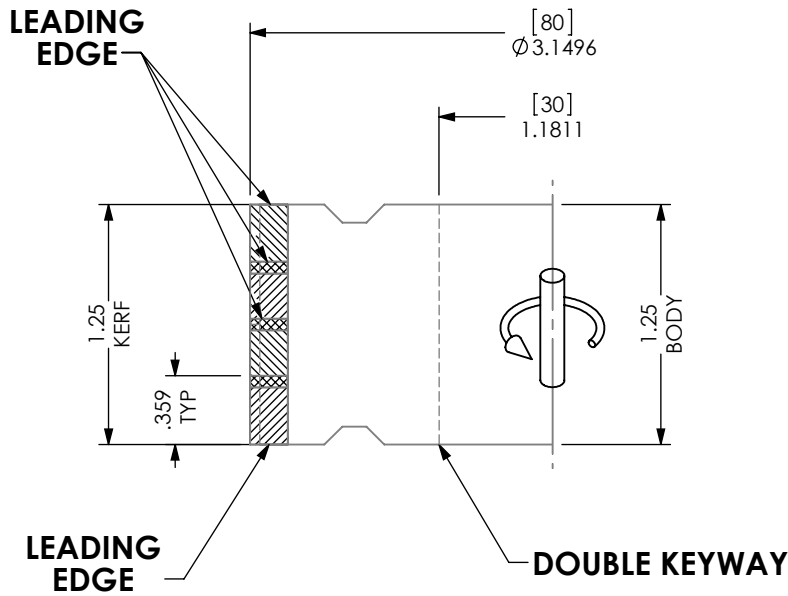

ATTN: \_\_\_\_\_

DATE: \_\_\_\_\_ PO#: \_\_\_\_\_

CUSTOM TOOLING MUST HAVE CUSTOMER APPROVAL PRIOR TO THE START OF MANUFACTURING. PLEASE REVIEW THIS DRAWING FOR ACCURACY, INCLUDING ROTATION, AND FAX A SIGNED AND DATED COPY TO 740-498-5454. PRODUCTION WILL BEGIN UPON RECEIPT OF APPROVED DRAWING.

APPROVED BY: \_\_\_\_\_ DATE: \_\_\_\_\_

CUSTOMER: HALL MANUFACTURING

DATE:  
3/26/14

DWN BY:  
R.A.Y.

REV.  
+

SHEET 1 OF 3

