

TEETH: 3
 HOOK: 12°
 SHEAR: 0°
 TIPS: INSERT
 PA: N/A

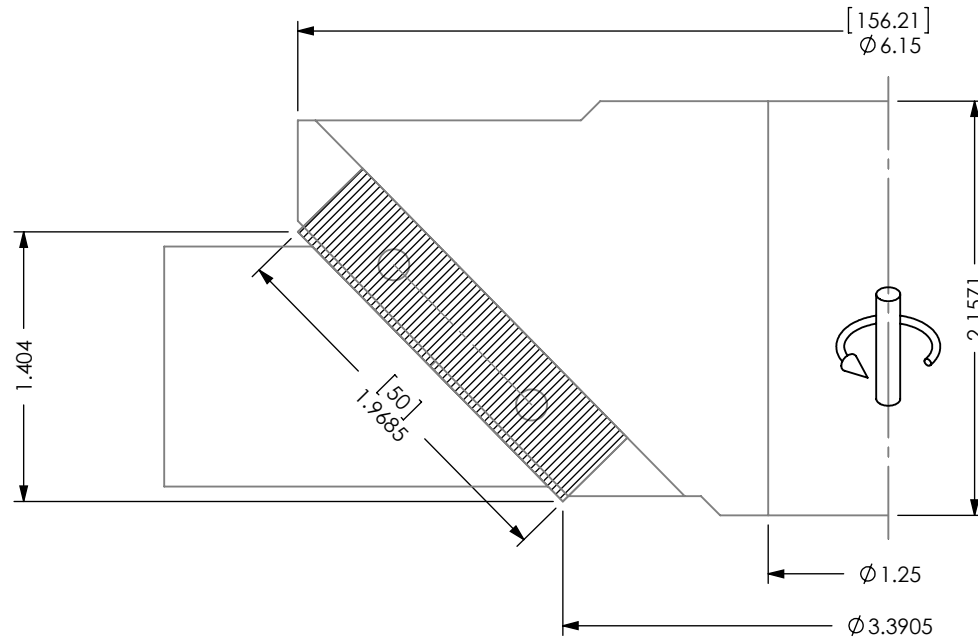
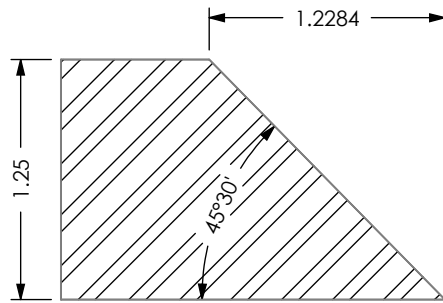

ATTN: _____ DATE: _____ PO#: _____

CUSTOM TOOLING MUST HAVE CUSTOMER APPROVAL PRIOR TO THE START OF MANUFACTURING. PLEASE REVIEW THIS DRAWING FOR ACCURACY, INCLUDING ROTATION, AND FAX A SIGNED AND DATED COPY TO 740-498-5454. PRODUCTION WILL BEGIN UPON RECEIPT OF APPROVED DRAWING.

APPROVED BY: _____ DATE: _____

THIS DRAWING CONTAINS CONFIDENTIAL AND PROPRIETARY INFORMATION AND IS THE PROPERTY OF H3D TOOL CORP. NEITHER THIS DRAWING NOR THE INFORMATION THEREON MAY BE USED FOR ANY PURPOSE OTHER THAN APPROVAL WITHOUT H3D TOOL CORP. WRITTEN CONSENT.

CUSTOMER: HALL MANUFACTURING

DATE:
3/19/14

DWN BY:
G.R.F.

REV. + SHEET 1 OF 5



H3D Tool Corp.
 High Definition Tooling
 Toll Free: 1-888-54HERCO (43726)
 Fax: 740-498-5454
 E-mail: sales@3d-diamond.com