

TEETH: <From Model>  
HOOK: <From Model>  
SHEAR: <From Model>  
TIPS: PCD  
PA: 32.877mm

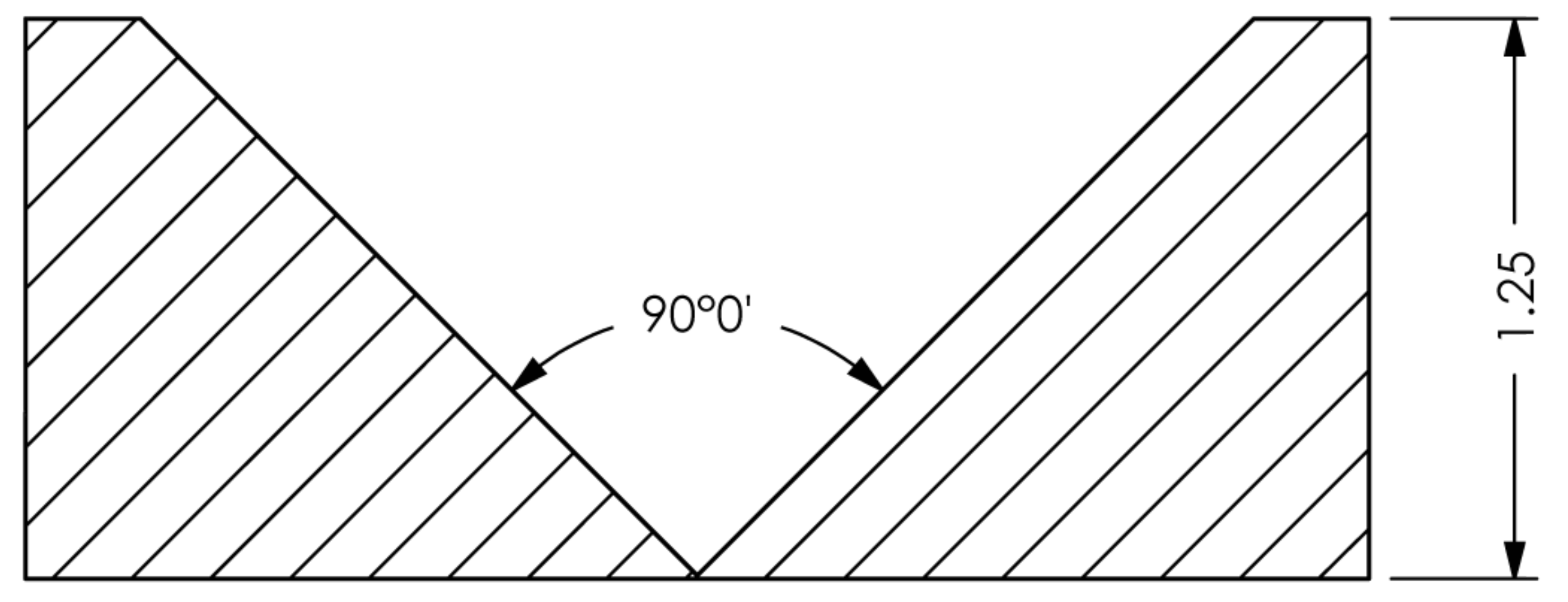
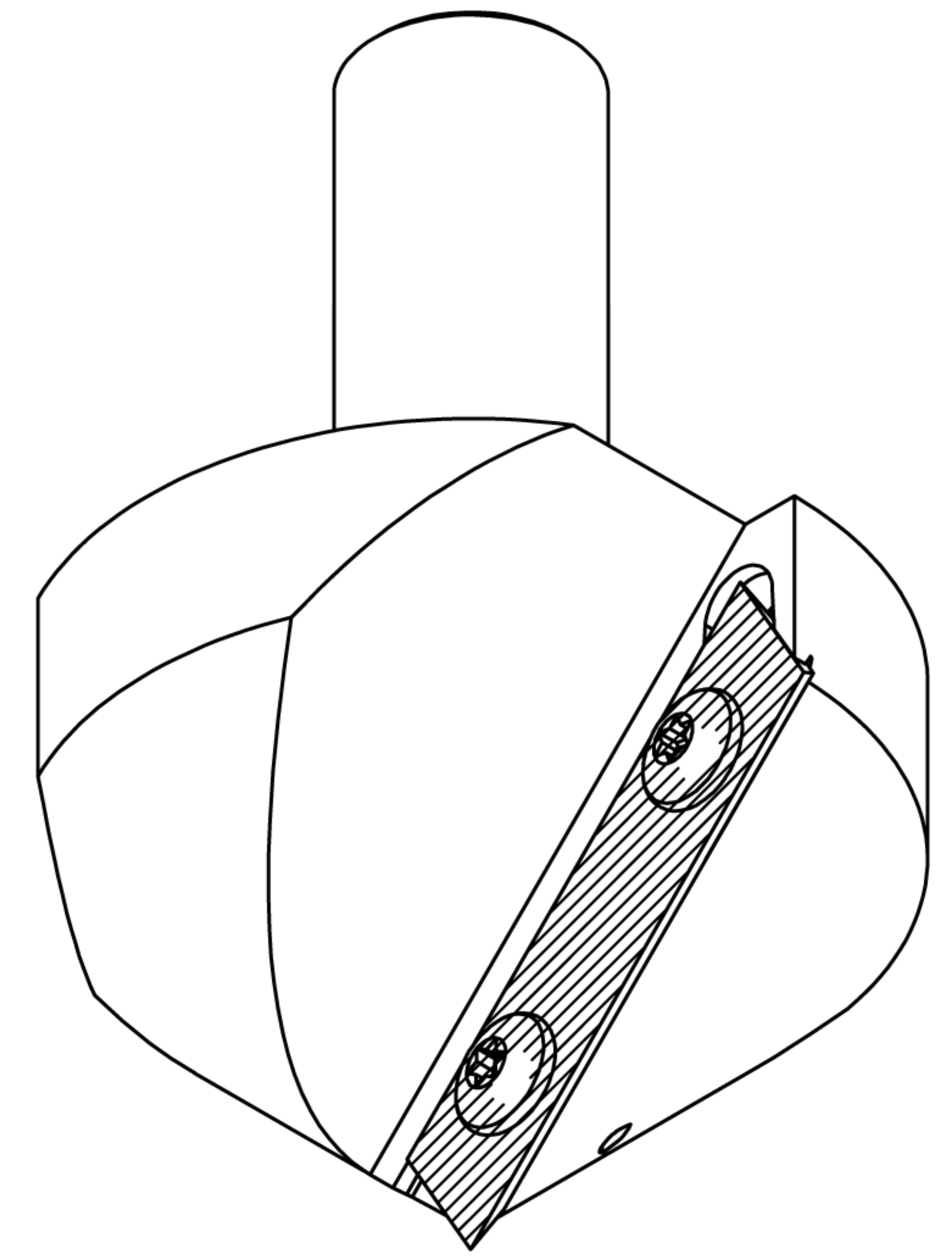
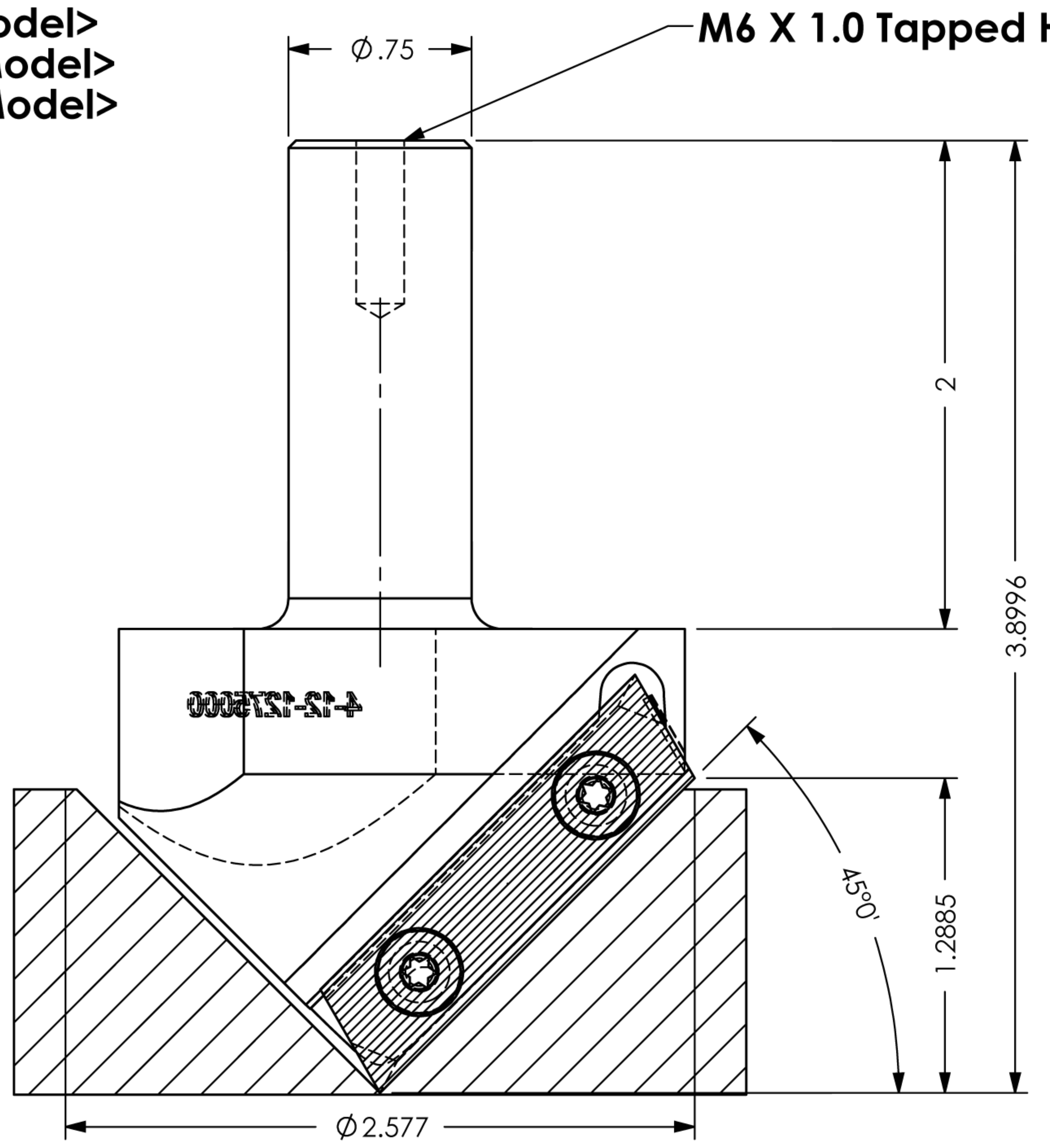

HALL MANUFACTURING DWG: 4-12-1275000

ATTN: \_\_\_\_\_ DATE: \_\_\_\_\_ PO#: \_\_\_\_\_

CUSTOM TOOLING MUST HAVE CUSTOMER APPROVAL PRIOR TO THE START OF MANUFACTURING. PLEASE REVIEW THIS DRAWING FOR ACCURACY, INCLUDING ROTATION, AND FAX A SIGNED AND DATED COPY. PRODUCTION WILL BEGIN UPON RECEIPT OF APPROVED DRAWING.

APPROVED BY: \_\_\_\_\_ DATE: \_\_\_\_\_

DATE:  
9/25/12

DWN BY:  
CJSR.A.Y.



REV.  
01

SHEET 1 OF 3