

TEETH: 2
HOOK: 0°
SHEAR: 5°
TIPS: PCD
PA: 32.877mm

DWG: 1-03-2349600

A.K.A. #: N/A

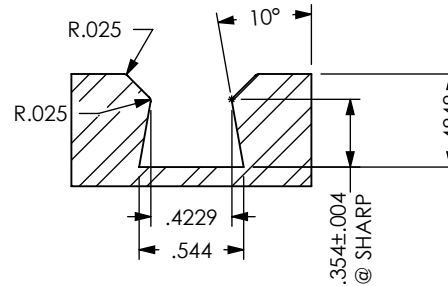
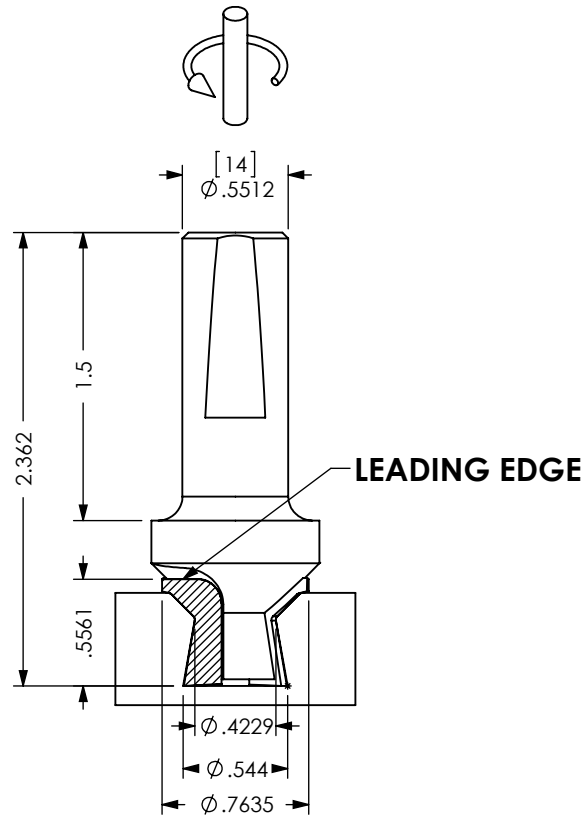

HALL MANUFACTURING DWG: 1-03-2349600

ATTN: _____ DATE: _____ PO#: _____

CUSTOM TOOLING MUST HAVE CUSTOMER APPROVAL PRIOR TO THE START OF MANUFACTURING. PLEASE REVIEW THIS DRAWING FOR ACCURACY, INCLUDING ROTATION, AND FAX A SIGNED AND DATED COPY. PRODUCTION WILL BEGIN UPON RECEIPT OF APPROVED DRAWING.

APPROVED BY: _____ DATE: _____

DATE:
9/26/12

DWN BY:
R.A.Y.



REV.
01

SHEET 1 OF 3