

TEETH: 2+1
HOOK: .156"/F/F & 0°
SHEAR: 0°/3°
TIPS: PCD
PA: 40.588mm

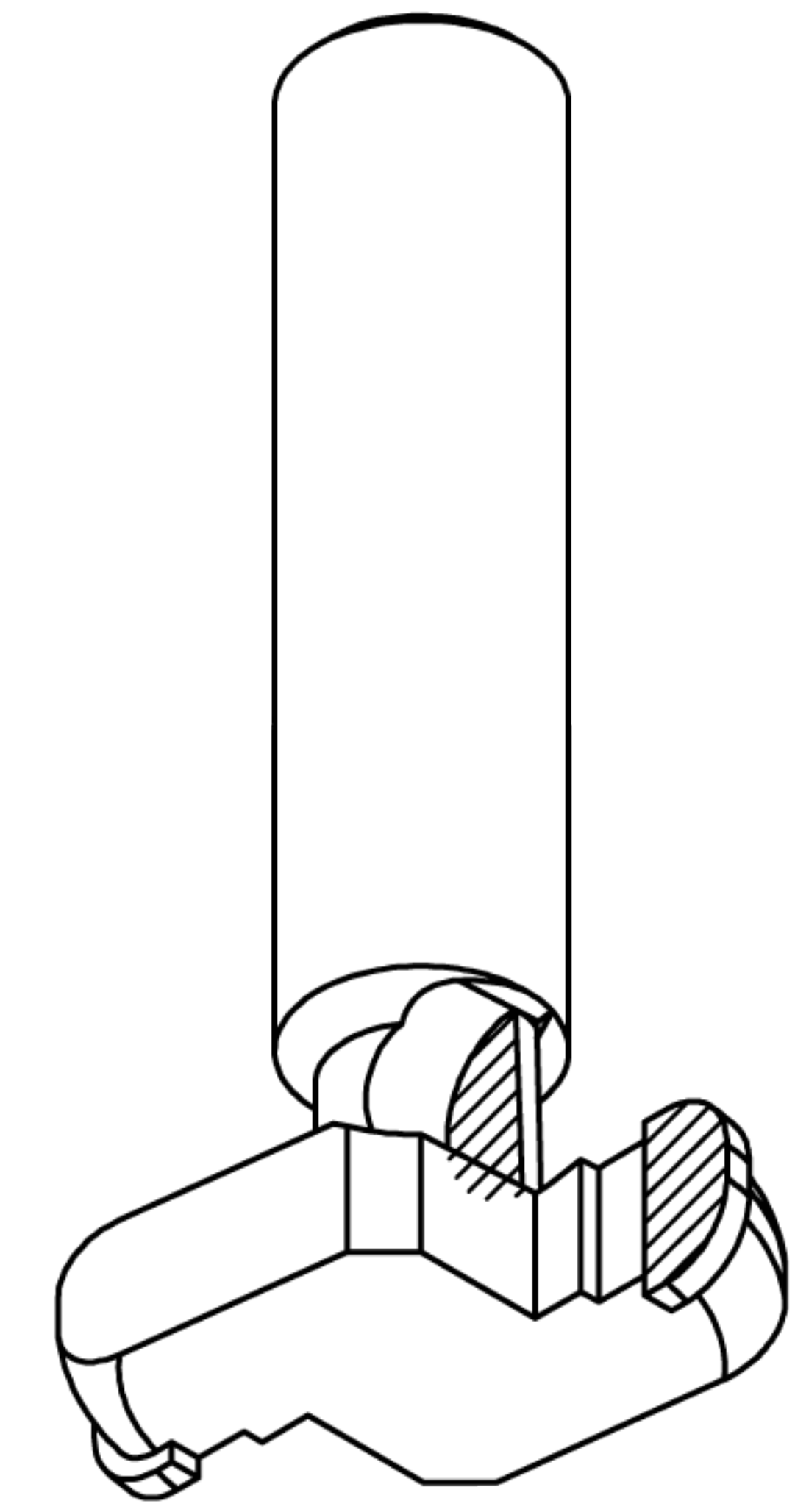
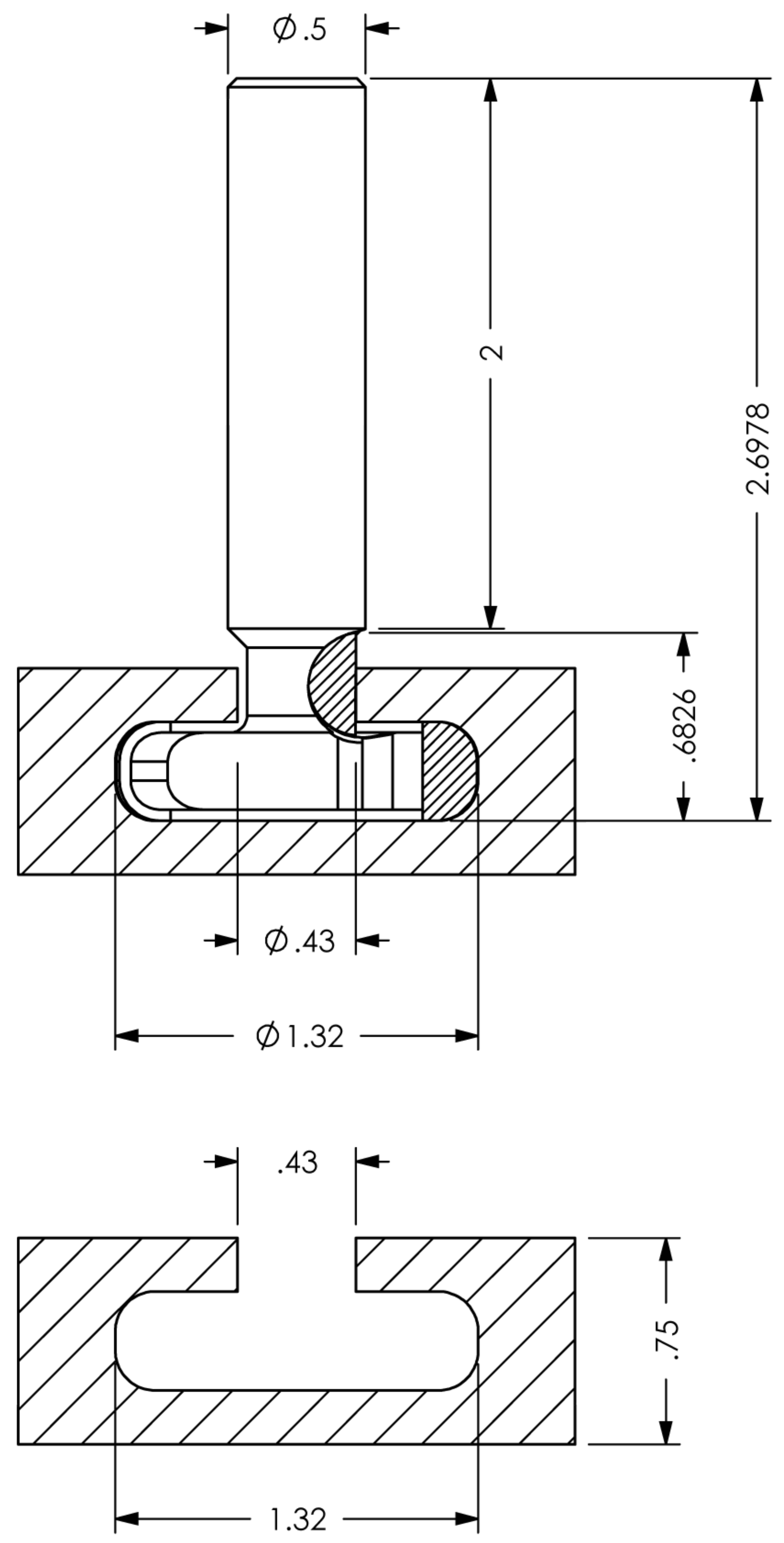

HALL-MAN DWG: 1-03-2005400

ATTN: _____ DATE: _____ PO#: _____

CUSTOM TOOLING MUST HAVE CUSTOMER APPROVAL PRIOR TO THE START OF MANUFACTURING. PLEASE REVIEW THIS DRAWING FOR ACCURACY, INCLUDING ROTATION, AND FAX A SIGNED AND DATED COPY. PRODUCTION WILL BEGIN UPON RECEIPT OF APPROVED DRAWING.

APPROVED BY: _____ DATE: _____

DATE:
4/20/11

DWN BY:
W.J.L.

SHEET 1 OF 3

