

3 Part Insert Adjustable Grooving Shaper Cutter with Scorer 4-15.5mm



Hard wearing steel body complete with tungsten carbide knives and scorer for improved finish. Suitable for producing various thickness grooves and slots in softwood, hardwood and man-made boards (with or without coating) on a spindle molder. Cutting width can be adjusted in 0.1mm steps by using supplied spacer rings.



EN847-1
EN847-2



Hand
Feed

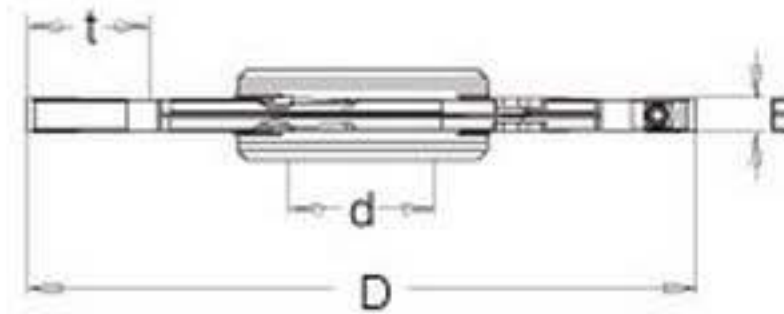

ØD	B	Tool No.	Teeth	Ød	Max. t	RPM
150	4.0-15.5	61354	2+2+4	1-1/4"	45	5,500-8,500

Replacement Parts



Description	T.C. Blade	Wedge	T.C. Blade	T.C. Blade	Spacer Set
Tool No.	AMA-17	WB-12	RCK-18	RCK-71	67208
Size	7.5x12x1.5	L=6.5	18x18x2	14x14x1.2	(B=7.1mm)



Description	Blade Nut	Torx® Screw	Hex Screw	Torx® Key	Torx® Key
Tool No.	67172	67056	67114	5090	5007
Size	M4x0.5x11.1	M4x0.5x9.9	M4x3.2	T9	S2.5