

Slot Cutter Set

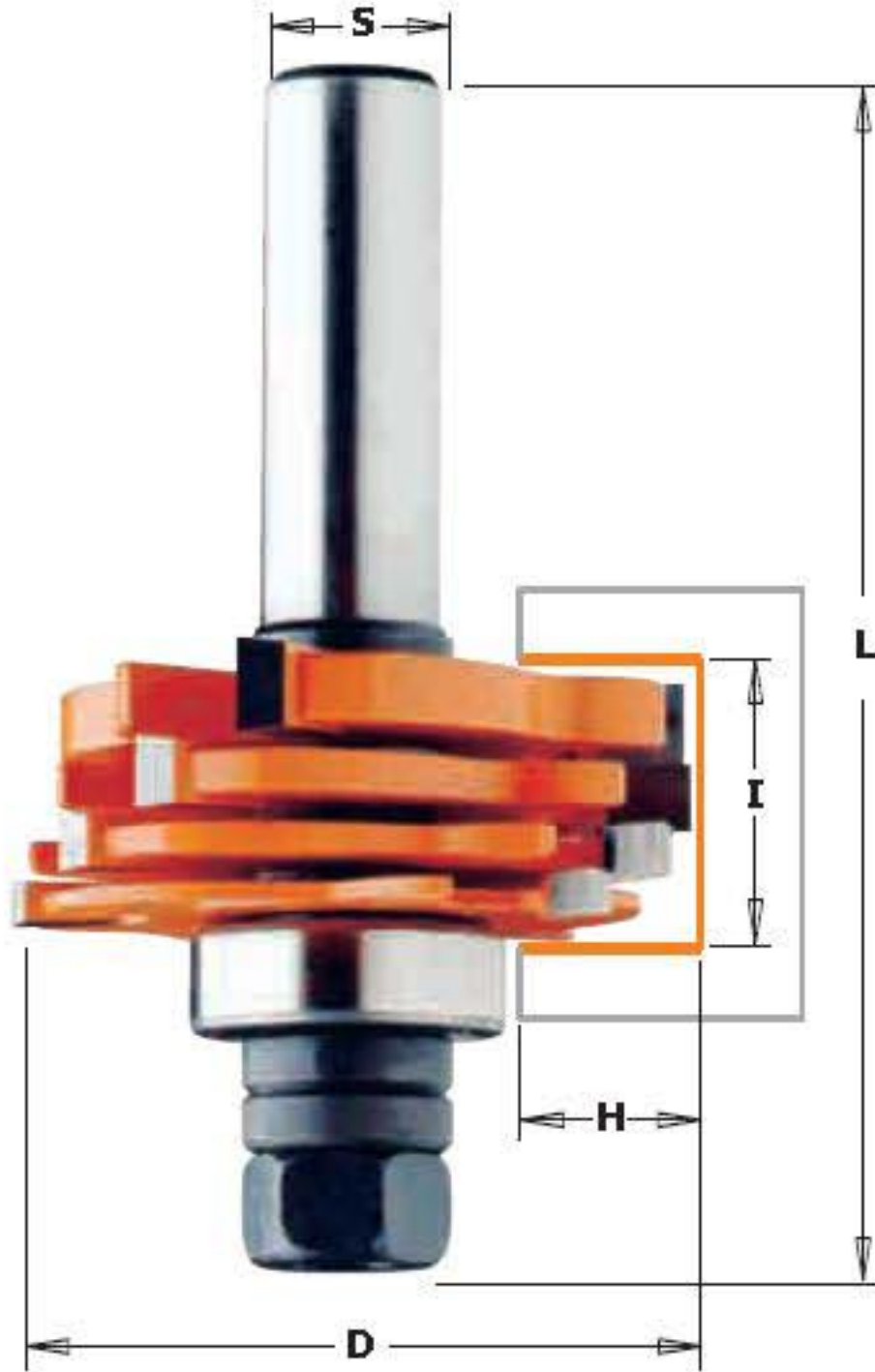

800.506

CMT's Three Wing Slot Cutter Set routs slots, grooves and rabbets from 1/8" to 23/32" deep. Ideal for biscuit joints and milling perfect tongue and groove joints.

The set includes:

- 4 carbide tipped cutters 1/8", 5/32", 3/16", 1/4"
- 1 arbor 1/2"
- 1 ball bearing (22mm) for 1/2" cut.
- 17 shims: (8 x 0.1mm, 4 x 0.5mm, 3 x 1mm, 2 x 4mm).

Safety Precautions:

Never use without shims between the cutters and between the cutter & bearing.

Shop Tips:

The bearings kit **791.711.00** allows to make 1/4" and 3/8" cutting depth.

Cutter combinations	Cutter height	
	inches	inches
A	0.126	
B	0.157	
C	0.189	
D	0.252	
A + B	0.252	to 0.279
A + C	0.283	to 0.311
A + D	0.346	to 0.374
B + C	0.315	to 0.342
B + D	0.378	to 0.405
C + D	0.409	to 0.437
A + B + C	0.409	to 0.464
A + B + D	0.468	to 0.523
A + C + D	0.500	to 0.555
B + C + D	0.531	to 0.586
A + B + C + D	0.626	to 0.708

Use shims to adjust cut width: MIN. 0.039" · MAX 0.066"

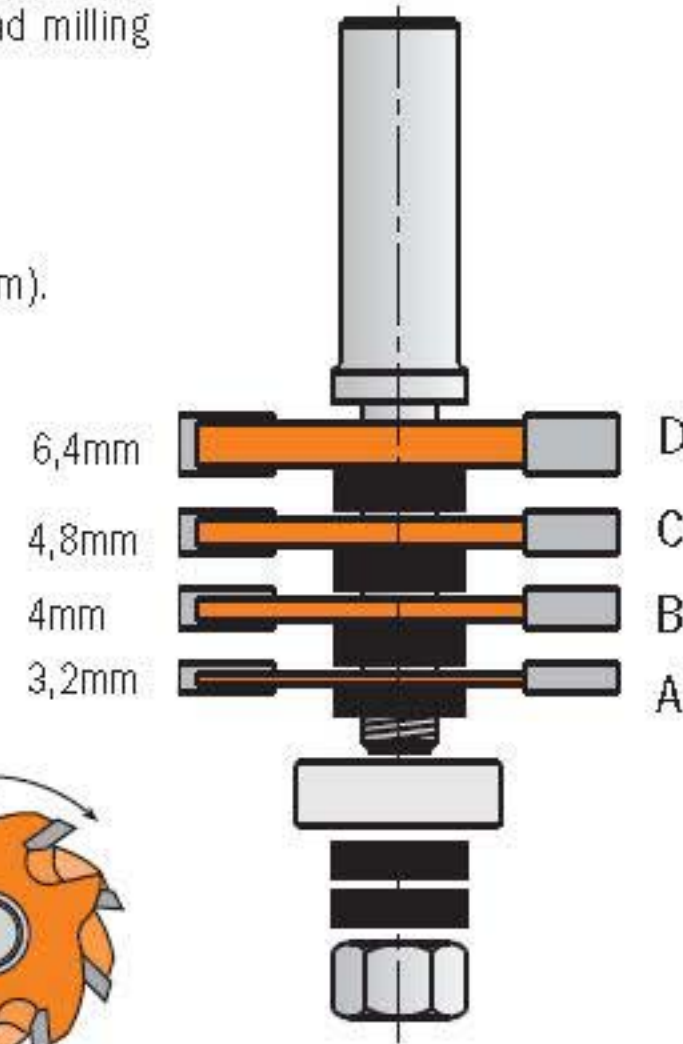

Note: the carbide edges of the cutters should never touch; arrange the shims as illustrated below. Use only the thicknesses provided in the set. Be sure all cutters are assembled in the proper rotational direction as shown below. Looking down the arbor the cutters will turn clockwise.

ORDER NO. 1/2" shank	I		D	H	L	Spare parts		
	inches	mm				Arbor with shims	Bearing	Nut M8
800.506.11	1/8 to 23/32	3.2-18	1-7/8	1/2	3-3/16	824.128.00	791.005.00	990.020.00

Spare parts
791.711.00 Kit of two bearing (1-1/8" & 1-3/8") for slot cutter
541.515.00 0.1mm spacer

541.517.00 0.5mm spacer
541.518.00 1mm spacer