



## 855.503 - 855.504

CMT lock miter bits are ideal for milling miter joints in 1-1/8" stock. The quick and easy way to accurately create boxes, stretcher bars, frames and any assortment of right angle or parallel joint projects.

To produce perfectly fitting miter joints, lay one piece with the inside face down on the work table and the wood centered to the bit. Mill as shown in step 1 of the illustration below. Mill the second piece with the inside face placed vertical to the bit and fence, as shown in step 2.

To mill sturdy parallel glue joints follow step 1 shown in the illustration with the inside face of the workpiece laid flat on the table and centered to the bit. To make the second part, lay the workpiece flat on the table and centered to the bit. Mill with the inside face up.

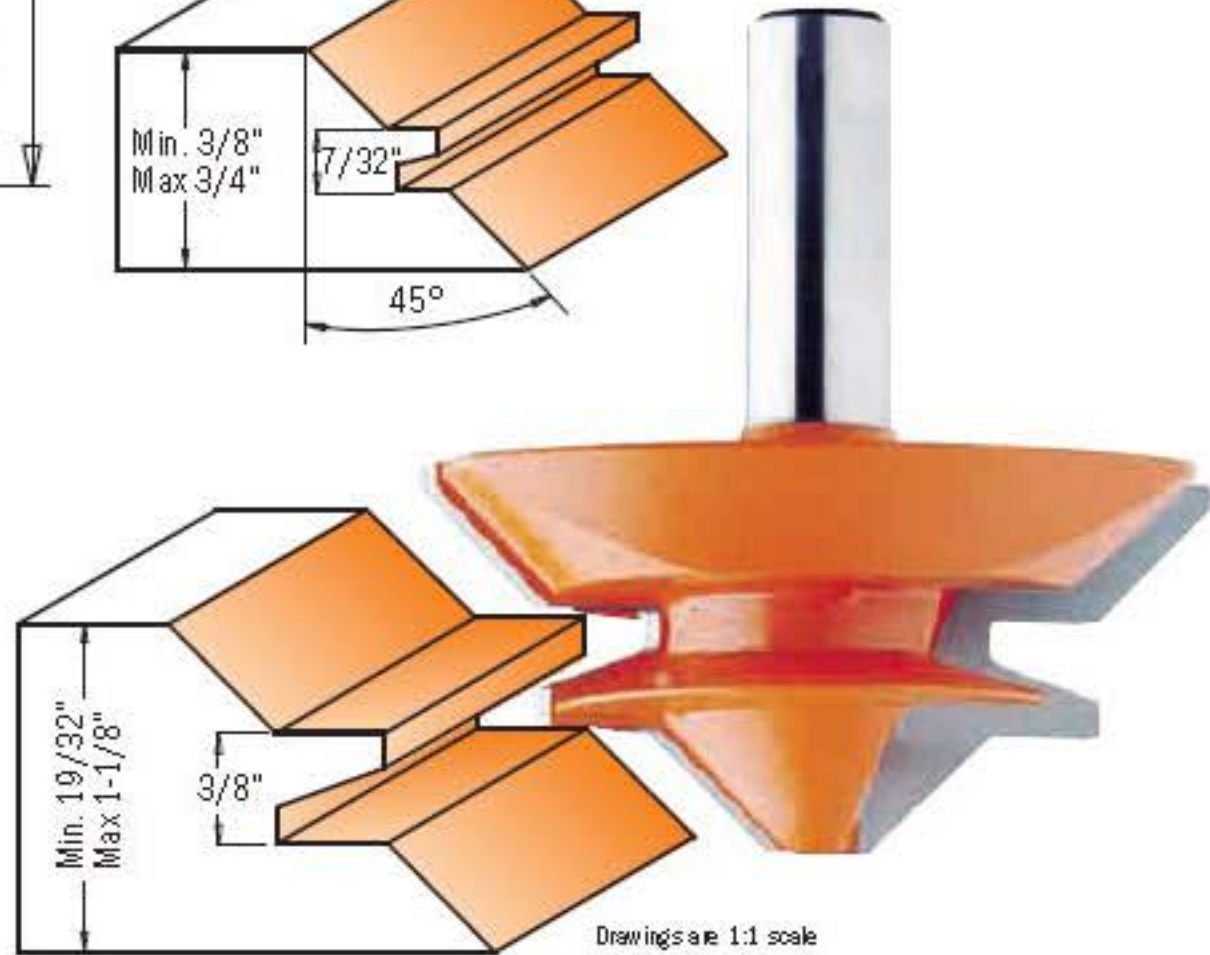
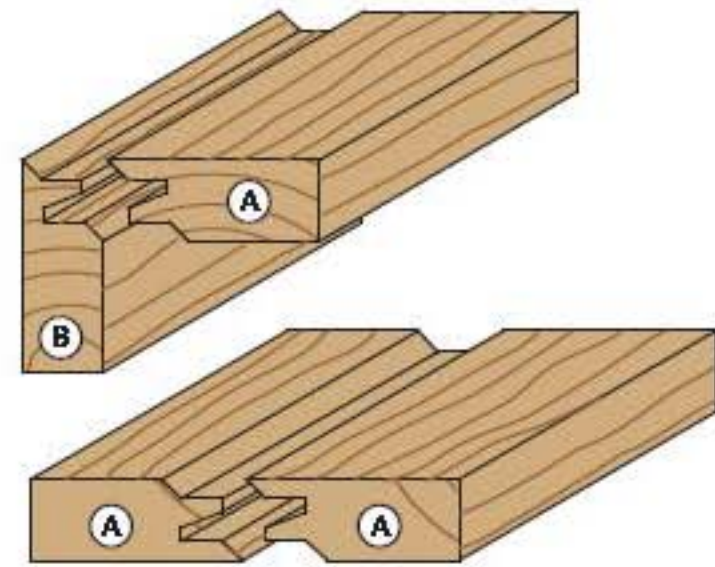
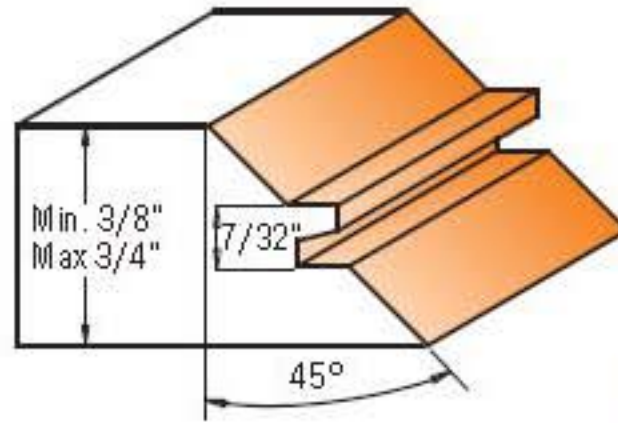
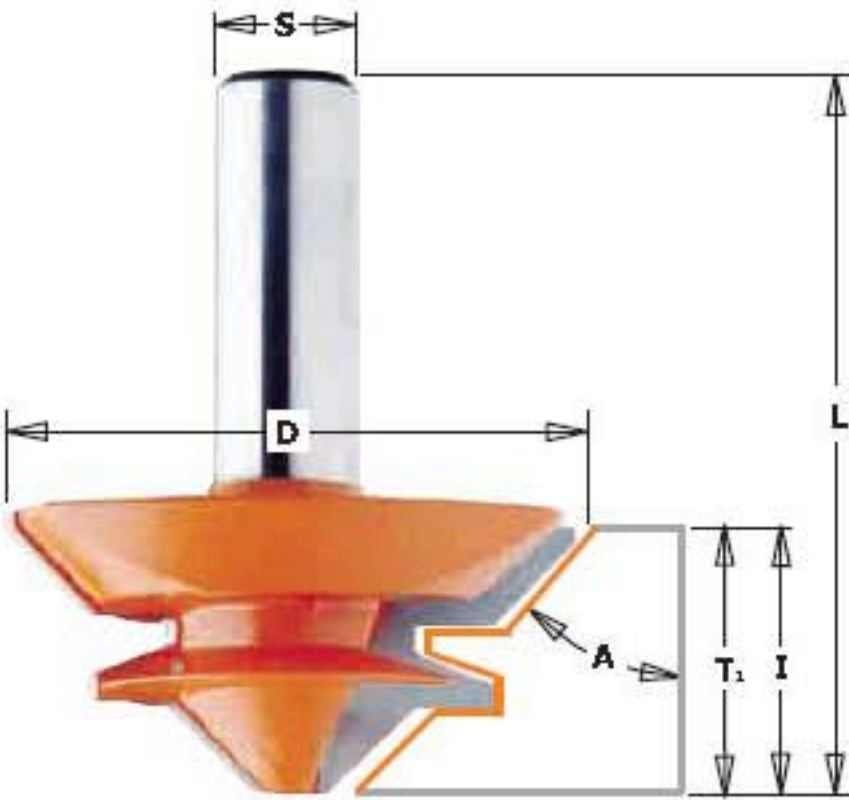

### TO MILL STURDY PARALLEL GLUE JOINTS

Follow the instructions in Step 1 and Fig. 1 below for the first piece of stock, routing the joint with the inside face of the workpiece laid flat on the table and centered to the bit. To rout the second piece of stock, lay the workpiece flat on the table and centered to the bit with the inside face up.

| ORDER NO.  | D      | I    | A      | T <sub>1</sub> | L         |
|------------|--------|------|--------|----------------|-----------|
| 1/2" shank | inches | mm   | inches | inches         | inches    |
| 855.503.11 | 2-3/4  | 69.8 | 1-1/4  | 45°            | 5/8-1-1/8 |
| 855.504.11 | 2      | 50.8 | 7/8    | 45°            | 3/8-3/4   |

### Miter and Glue Joints with the Lock Miter Bit

Example shown below is made using Lock Miter Bit 855.503.11 and 3/4" stock.

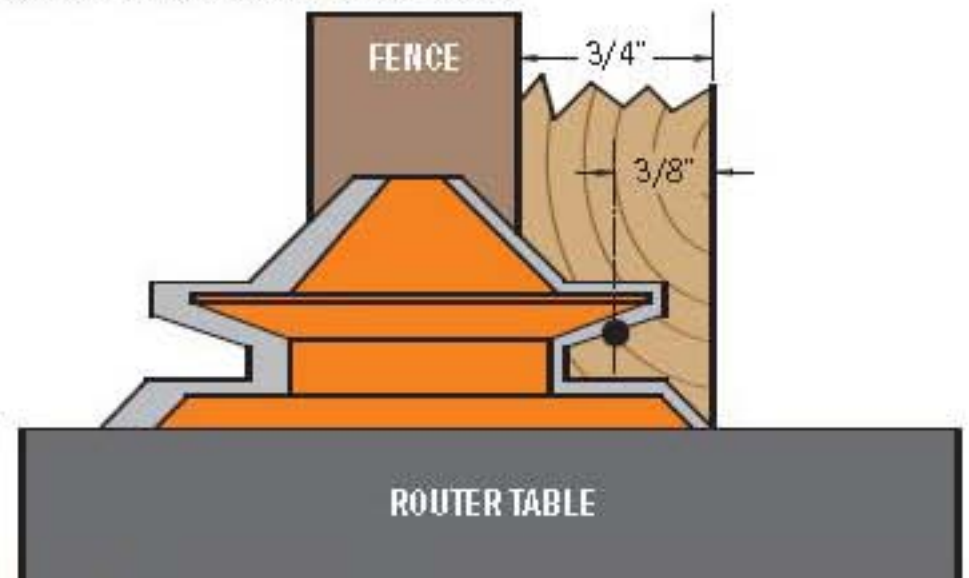
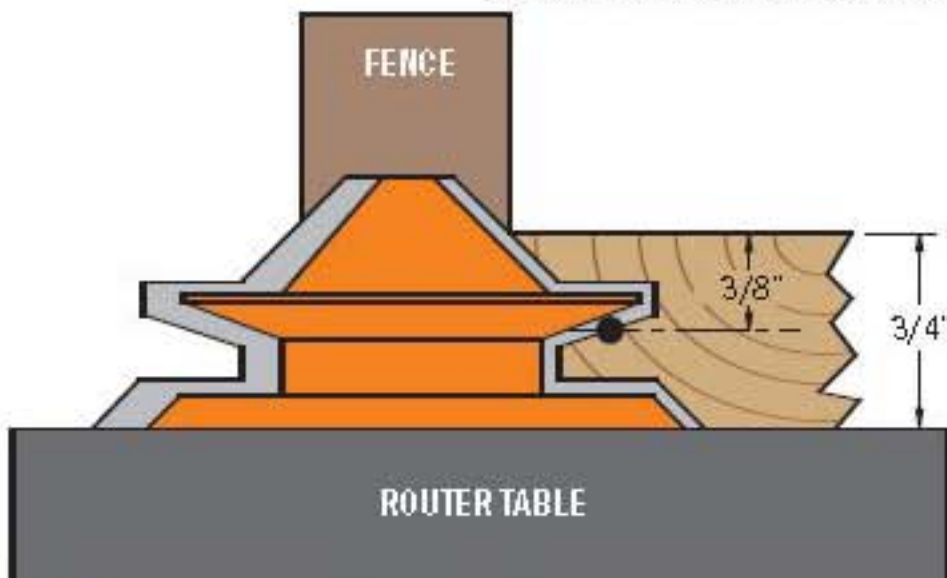

**Step 1:** Rout the first piece of stock with the inside face down on the work table and the wood centered to the bit. Mill as shown in Fig. 1 of the illustration. Use pusher blocks or a pusher stick to control the workpiece, and use featherboards attached to both the fence and table to hold the workpiece in position.

**Step 2:** Mill the second workpiece with the inside face of the stock placed against the fence and vertical in relation to the router table, as shown in Fig. 2. Use pusher blocks to move the workpiece, and use featherboards or other hold-in devices to keep the stock firmly against the fence.