

Rounding Over Bits

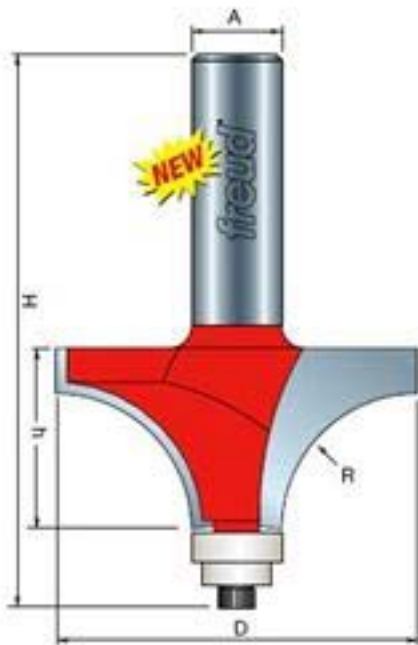

Application: Rout rounded top edges, or use with Under Rounding Bits to create bull nose profiles

- Use to rout a round over, or in combination with the Under Rounding Bits with the same radius below to rout a bull nose.
- Specially formulated carbide is ideal for fabricating solid surface materials.
- Features non-marring synthetic bearing to protect finished edges.
- Cuts all solid surface materials.
- Use in hand-held portable routers.



85-342

A full bull nose profile can be created by using the Under Rounding Bit (previous page) to create the bottom round over profile and use the above Rounding Over Bit to create the top round over profile.

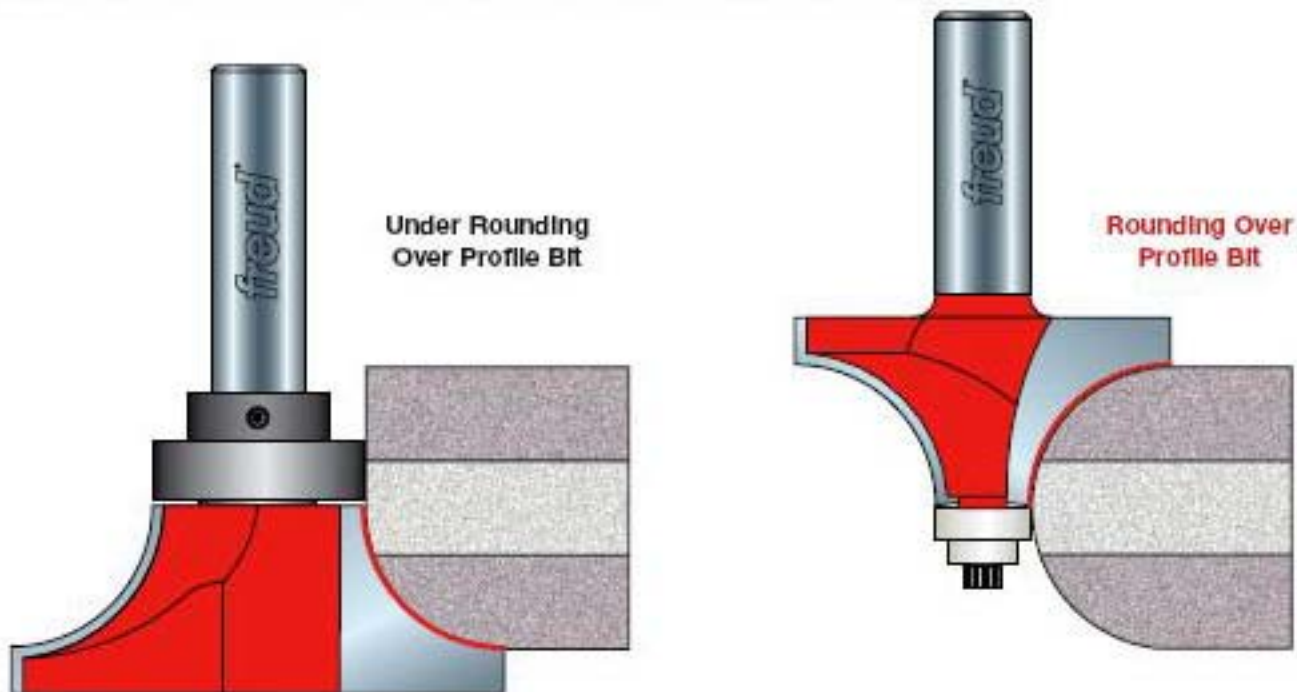

Item #	For Top Thickness	Overall Dia.(D)	Carbide Height(h)	Large Radius(R)	Shank Dia.(A)	Overall Length(H)
85-342	1/2"	1"	3/8"	1/4"	1/2"	2-3/8"
85-362	3/4"	1-1/4"	1/2"	3/8"	1/2"	2-1/2"
85-372	1"	1-1/2"	3/4"	1/2"	1/2"	2-3/4"
85-382	1-1/2"	2"	1"	3/4"	1/2"	3"