

Carbide Forstner Bits

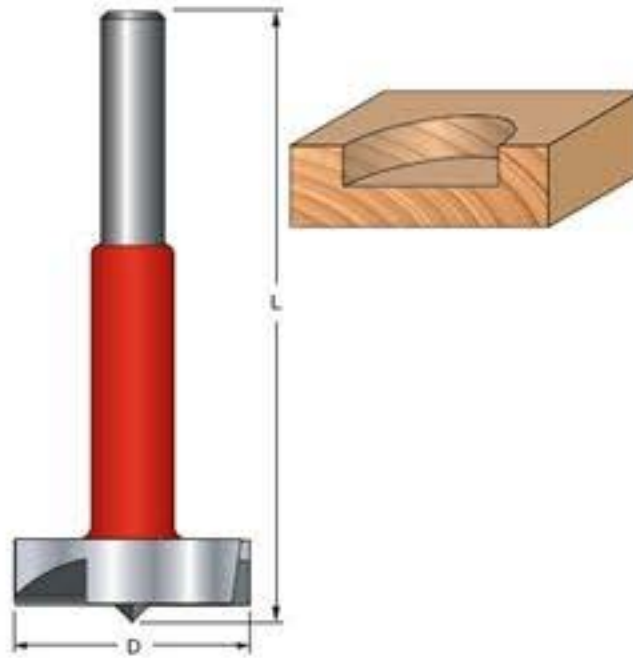

Freud's Carbide Forstner Bits bring a technical level of excellence not found in a standard high speed steel Forstner Bit. These bits will drill through a multitude of materials. Use to drill pocket holes, angled holes, overlapping holes and flat bottom holes. Best of all, these bits will not burn like a standard forstner and will stay sharp many times longer. These bits can be sharpened by any reputable sharpening service who sharpens router bits.

Application:

Drills all composition materials, plywoods, hardwoods, solid surface materials, and softwoods. Use in hand held drills and drill presses.

Item #	Cut Dia.(D)	Overall Length(L)	Shank Diameter
FC-001	1/4"	3-7/16"	5/32"
FC-002	3/8"	3-7/16"	1/4"
FC-003	1/2"	3-15/32"	5/16"
FC-004	5/8"	3-1/2"	5/16"
FC-005	3/4"	3-1/2"	3/8"
FC-006	7/8"	3-1/2"	3/8"
FC-007	1"	3-1/2"	3/8"
FC-008	1-1/8"	3-1/2"	3/8"
FC-009	1-1/4"	3-1/2"	3/8"
FC-010	1-3/8"	3-1/2"	3/8"
FC-011	1-1/2"	3-1/2"	3/8"
FC-012	1-5/8"	3-1/2"	3/8"
FC-013	1-3/4"	3-1/2"	3/8"
FC-014	1-7/8"	3-1/2"	3/8"
FC-015	2"	3-1/2"	3/8"
FC-016	2-1/8"	3-1/2"	3/8"

Rotation = Right