



694.013



We offer you the traditional approach to panel construction with the CMT raised panel cutter head. Make your classic raised panels on furniture, interior and cabinet doors in solid wood and wooden boards, obtaining three different profiles adjusting the cutting depth. Multiple passes are recommended to safely and accurately obtain the perfect finish. Excellent results in most materials but ideal for hardwood, soft wood and wooden veneer board.

Technical details:

- Heavy duty aircraft aluminum body
- 2 solid carbide Knives type (A) 19,8x11,9x1,5mm [Z2]
- 2 solid carbide Knives type (B) 60x11,9x1,5mm [Z2]
- Tools for manual feed MAN
- Pins for the automatic positioning of the knives

Supplied in a solid plastic box.

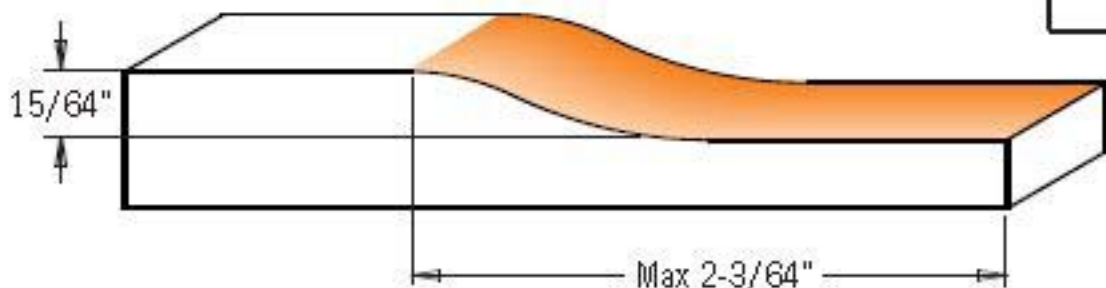
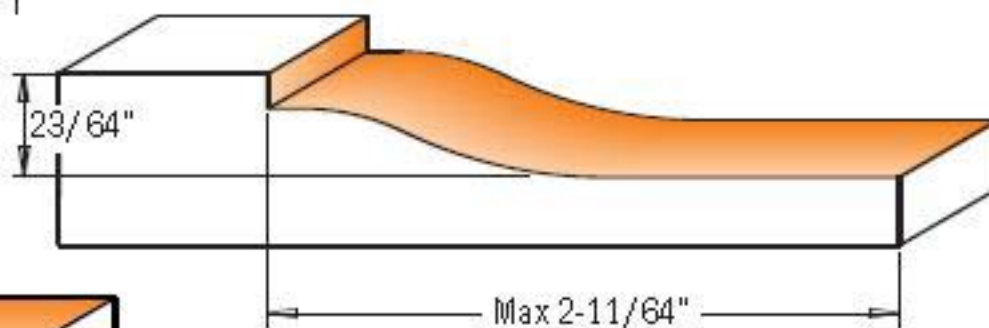
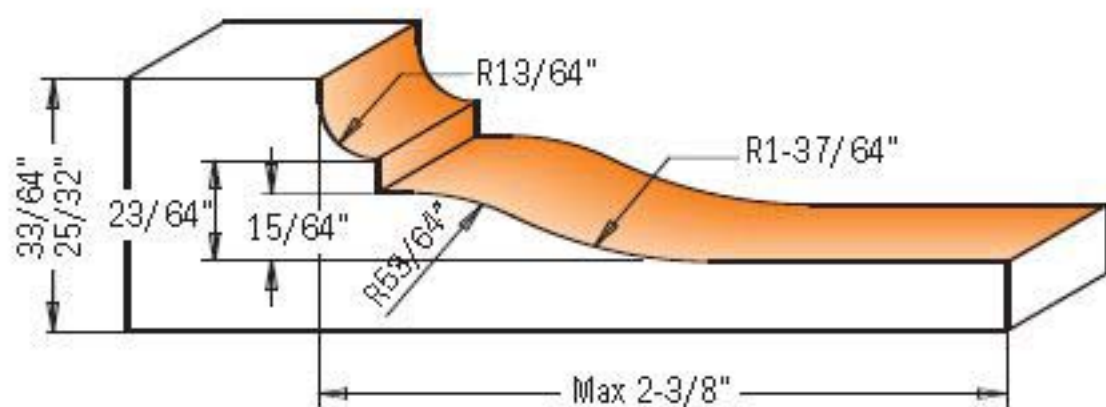
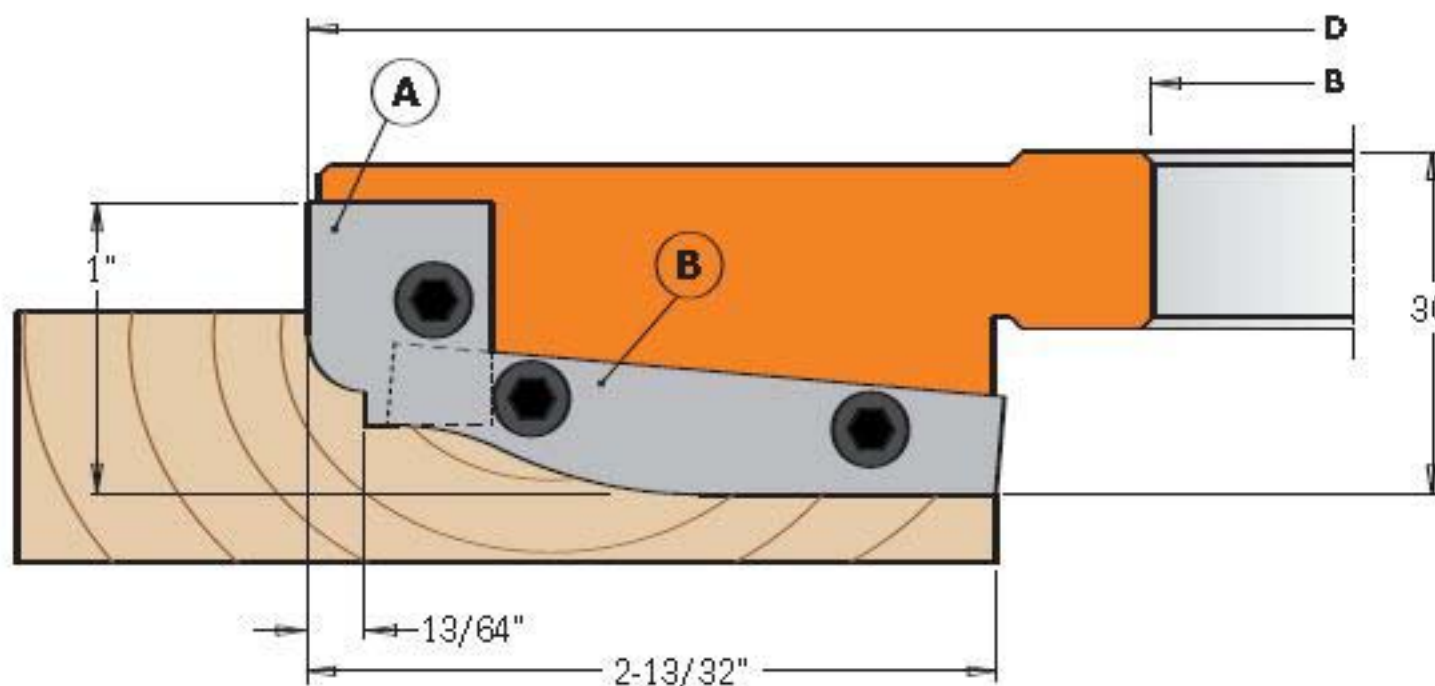

Drawings are 1:1 scale