

Insert Carbide Rabbeting Bit

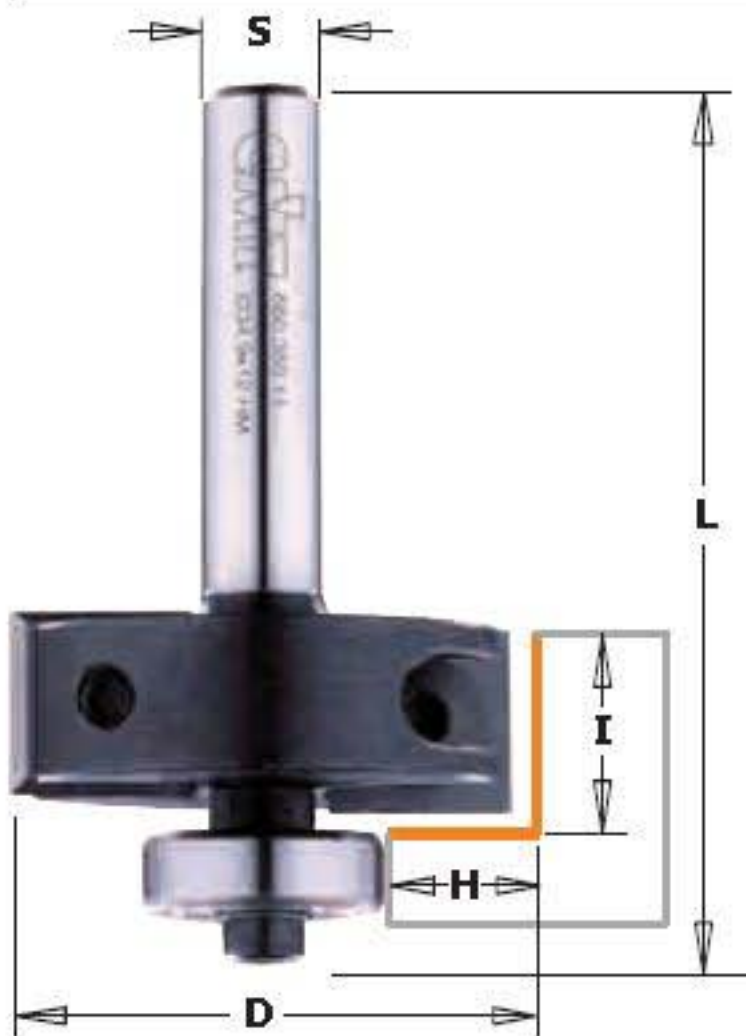

660

Primarily for use with portable routers, these rabbeting bits can be used with various bearings to produce a wide range of cut depths. Inserts are sharpened on all 4 sides.



Standard

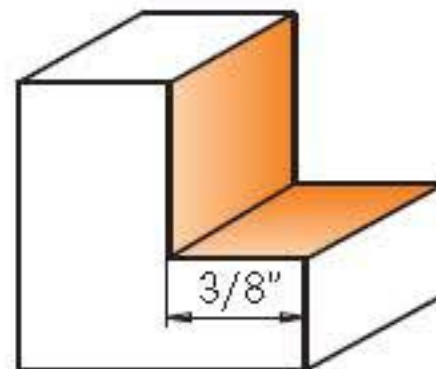

with bearing
791.018.00

Optional

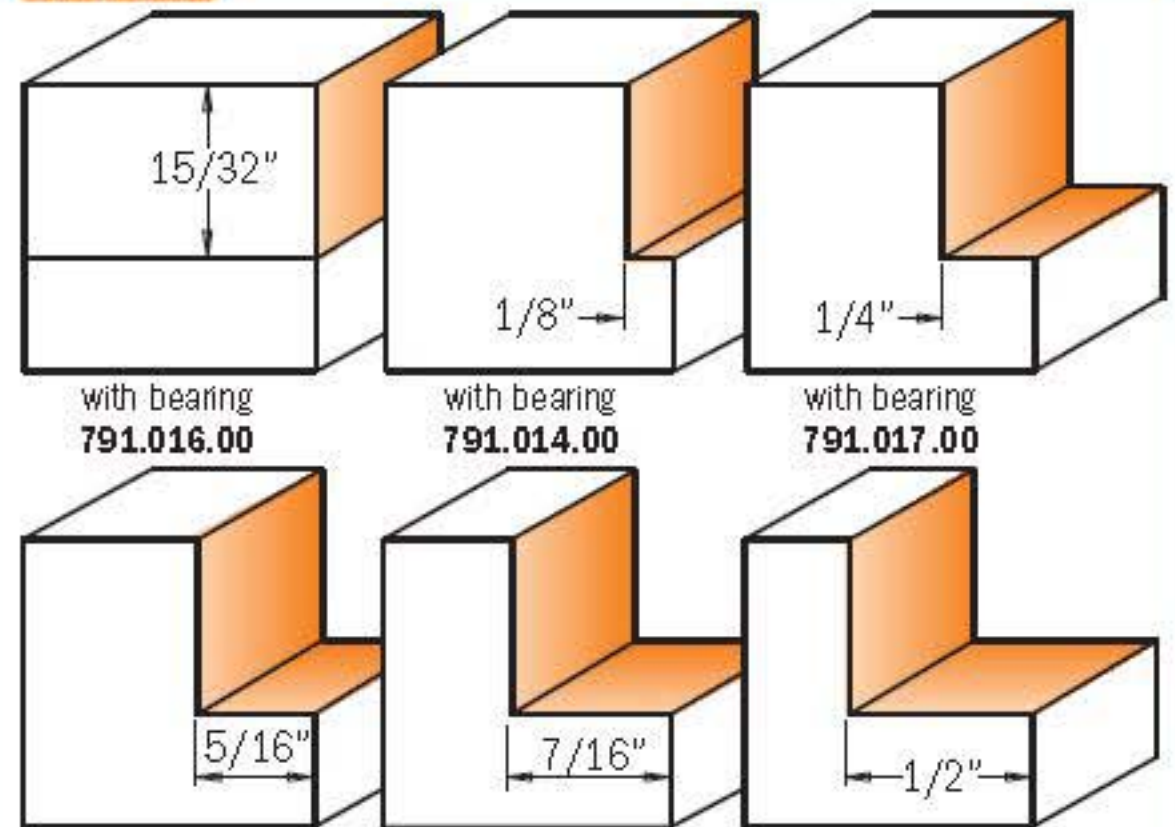

Drawings are 1:1 scale

ORDER NO. 1/4" shank	ORDER NO. 1/2" shank	H		D	I	L	Spare parts			
		inches	mm				Knives	Screw Torx	Key Torx	Bearing
660.351.11		3/8	9.5	1-3/8	15/32	2-11/64	790.120.00	990.075.00	991.061.00	791.018.00
	660.851.11	3/8	9.5	1-3/8	15/32	2-9/16	790.120.00	990.075.00	991.061.00	791.018.00

Spare parts

990.400.00 Washer 3.2/7mm fro screw M3 (bearing 791.002.00 - 791.003.00 - 791.018.00 - 791.019.00)

541.552.00 Washer 3.25/15.87mm fro screw M3 (bearing 791.016.00 - 791.014.00 - 791.017.00)

990.051.00 Screw TCEI M3x6mm for bearing (for bearing 791.002.00 - 791.003.00 - 791.018.00)

990.053.00 Screw TCEI M3x10mm for bearing (for bearing 791.014.00 - 791.017.00 - 791.019.00)

990.054.00 Screw TCEI M3x16mm for bearing (for bearing 791.016.00)

991.062.00 2.5mm hex key