

GEOMETRY
2 Wing(s)
10° Hook
5° Shear

Setup for profile D 2.25" wood

The minor diameter is 90mm

1. Spacer .4865" thick
2. Body 327A with insert 345
3. Groover body 327B
4. Spacer * .4475 thick
5. Groover body 327C
6. Body 327E with insert 346
7. End cap

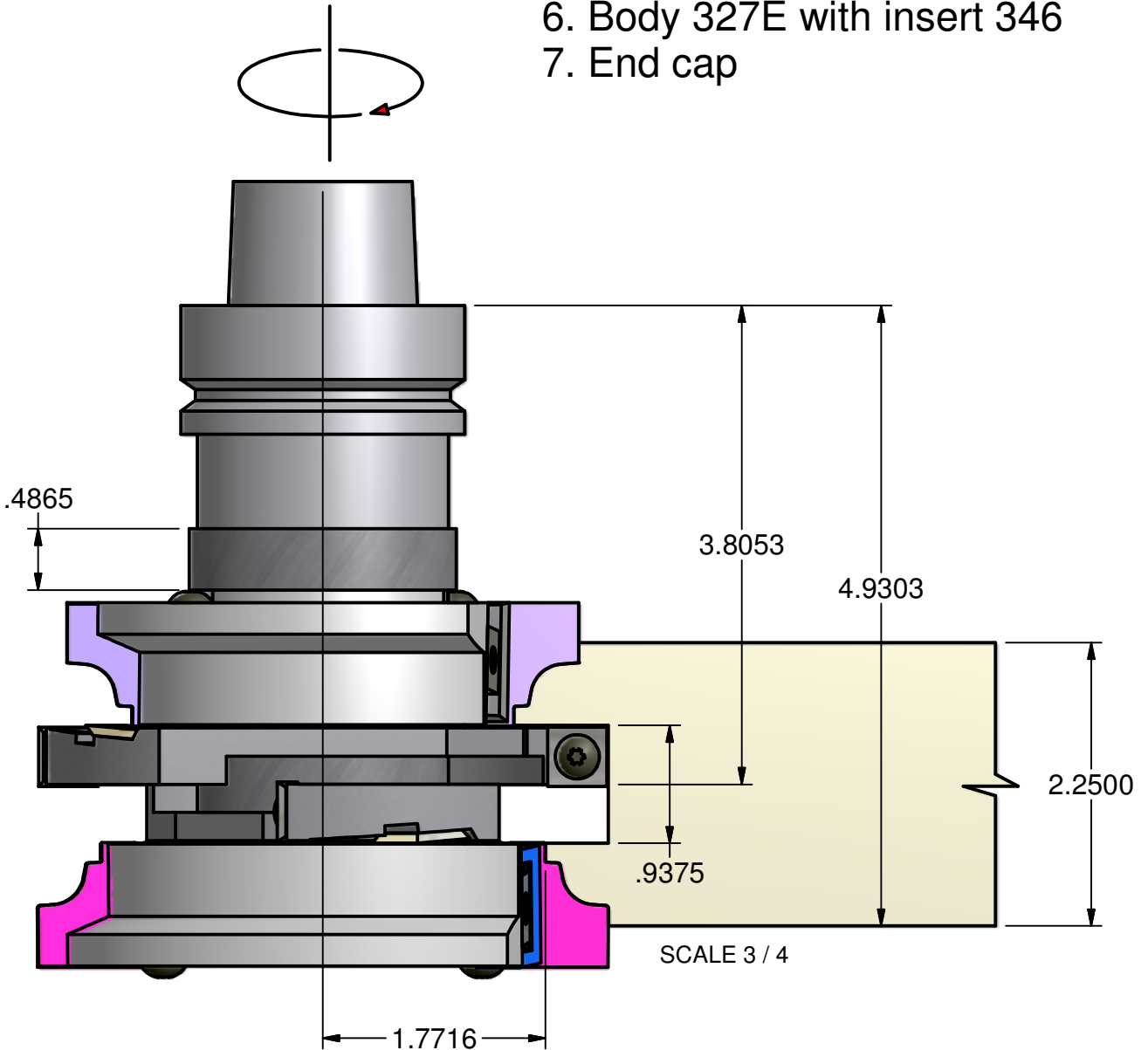

THIS DRAWING IS PROPERTY OF EW TOOLING, INC. AND MUST NOT BE USED IN ANY WAY DETRIMENTAL TO OUR INTERESTS

PARTS LIST DRAWING

E.W. TOOLING, INC.
Cutting tools for the woodworking industry

Originate: 12/09

Last edit: 12/14/09

EW P/N: 182-327

Tips: Carbide inserts

Cust P/N: Profile D for 2.25" wood

GEOMETRY
2 Wing(s)
10° Hook
5° Shear

Setup for profile D 2.25" wood

1. Spacer .4158" thick
2. Body 338A with 50 x 12 x 1.5 indexable insert
3. Body 338B with insert 347
4. End cap

The minor diameter is 3.792"

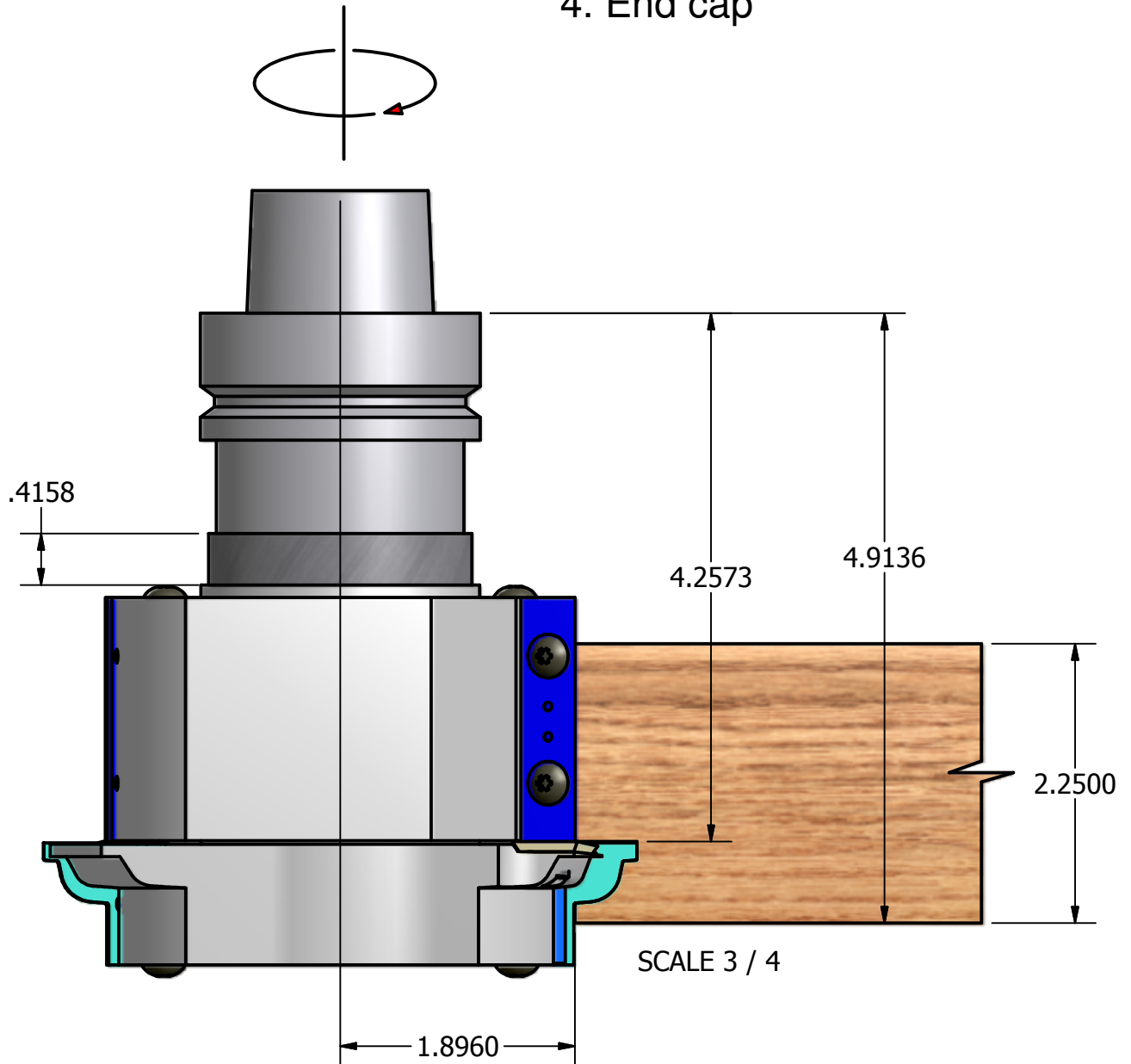

THIS DRAWING IS PROPERTY OF EW TOOLING, INC. AND MUST NOT BE USED IN ANY WAY DETRIMENTAL TO OUR INTERESTS

PARTS LIST DRAWING

E.W. TOOLING, INC.
Cutting tools for the woodworking industry

Originate: 12/09

Last edit: 12/14/09

EW P/N: 182-338

Tips: Carbide inserts

Cust P/N: Profile D for 2.25" wood