

GEOMETRY	
2	Wing(s)
10°	Hook
5°	Shear

Setup for profile C 1.75" wood

The minor diameter is 90mm

1. Spacer .7365" thick
2. Body 327A with insert 342
3. Groover body 327 B
4. Spacer .1975 thick
5. Groover body 327 C
6. Body 327E with insert 343
7. End cap

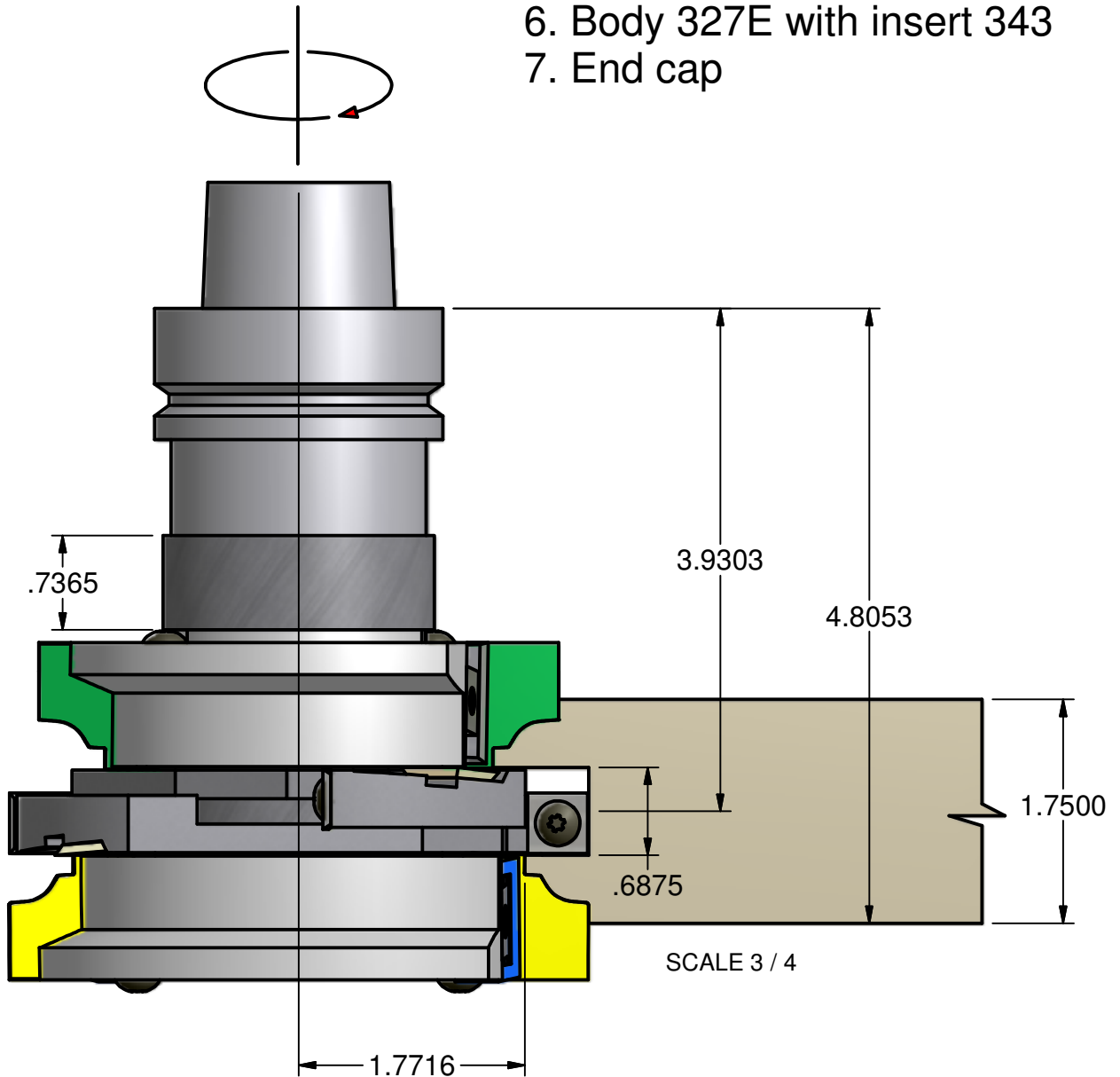

THIS DRAWING IS PROPERTY OF EW TOOLING, INC. AND MUST NOT BE USED IN ANY WAY DETRIMENTAL TO OUR INTERESTS

## PARTS LIST DRAWING

**E.W. TOOLING, INC.**  
Cutting tools for the woodworking industry

Originate: 12/09

Last edit: 12/14/09

EW P/N: 182-327

Tips: Carbide inserts

Cust P/N: Profile C for 1.75" wood

<b>GEOMETRY</b>	
2	Wing(s)
10°	Hook
5°	Shear

The minor diameter is 3.792"

Setup for profile C 1.75" wood

1. Spacer .4158" thick
2. Body 338A with 50 x 12 x 1.5 indexable insert
3. Body 338B with insert 344
4. End cap

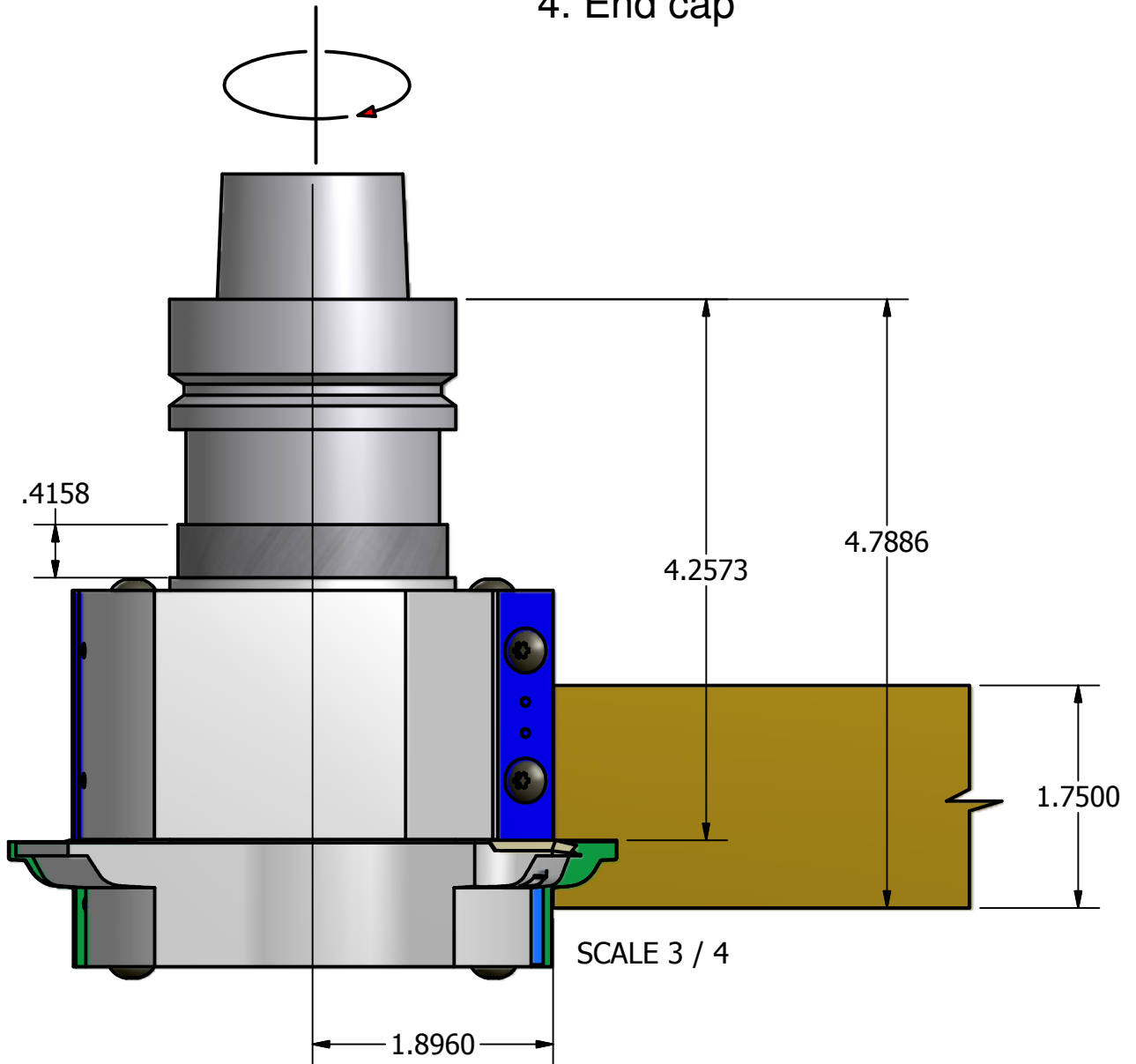

THIS DRAWING IS PROPERTY OF EW TOOLING, INC. AND MUST NOT BE USED IN ANY WAY DETRIMENTAL TO OUR INTERESTS

## PARTS LIST DRAWING

**E.W. TOOLING, INC.**  
Cutting tools for the woodworking industry

Originate: 12/09

Last edit: 12/14/09

EW P/N: 182-338

Tips: Carbide inserts

Cust P/N: Profile C for 1.75" wood