

GEOMETRY	
2	Wing(s)
10°	Hook
5°	Shear

Setup for profile B 1.75" wood

1. Spacer 1.1115" thick
2. Body 327A with insert 340
3. 1.25 x .005 shim
4. Brazed groover body 332
5. 1.25 x .005 shim
6. Body 327E with insert 341
7. End cap

The minor diameter is 90mm

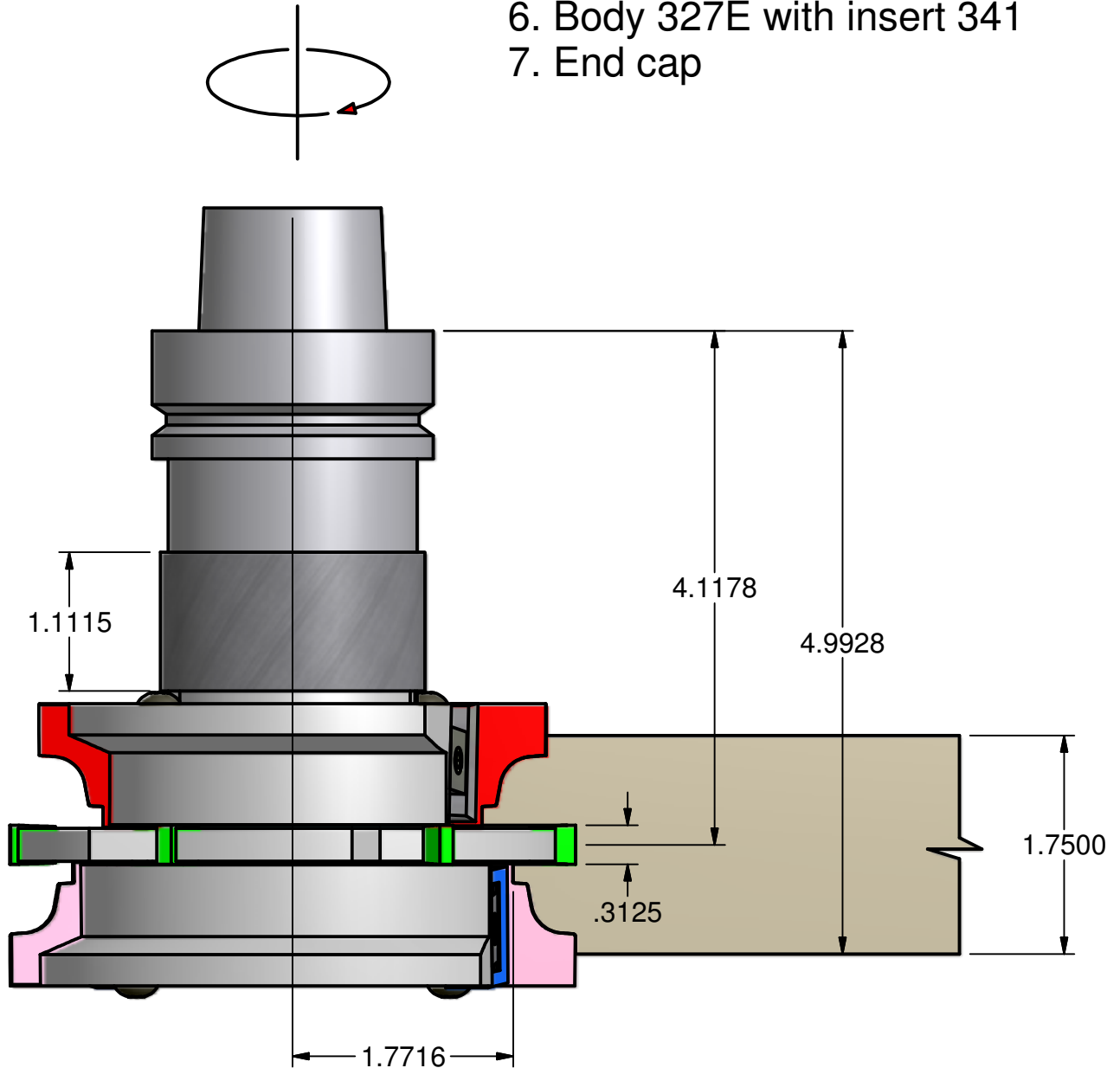

THIS DRAWING IS PROPERTY OF EW TOOLING, INC. AND MUST NOT BE USED IN ANY WAY DETRIMENTAL TO OUR INTERESTS

PARTS LIST DRAWING

E.W. TOOLING, INC.
Cutting tools for the woodworking industry

Originate: 12/09

Last edit: 12/14/09

EW P/N: 182-327

Tips: Carbide inserts

Cust P/N: Profile B for 1.75" wood

GEOMETRY
2 Wing(s)
10° Hook
5° Shear

The minor diameter is 90mm

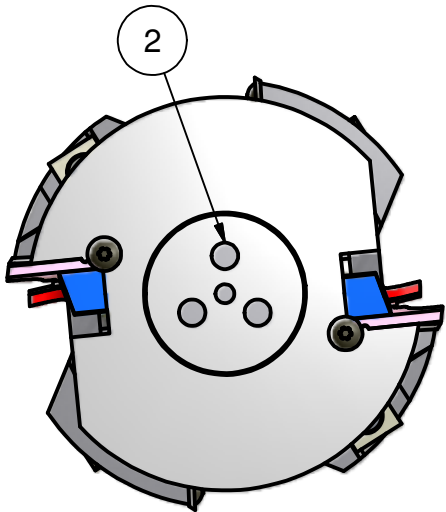
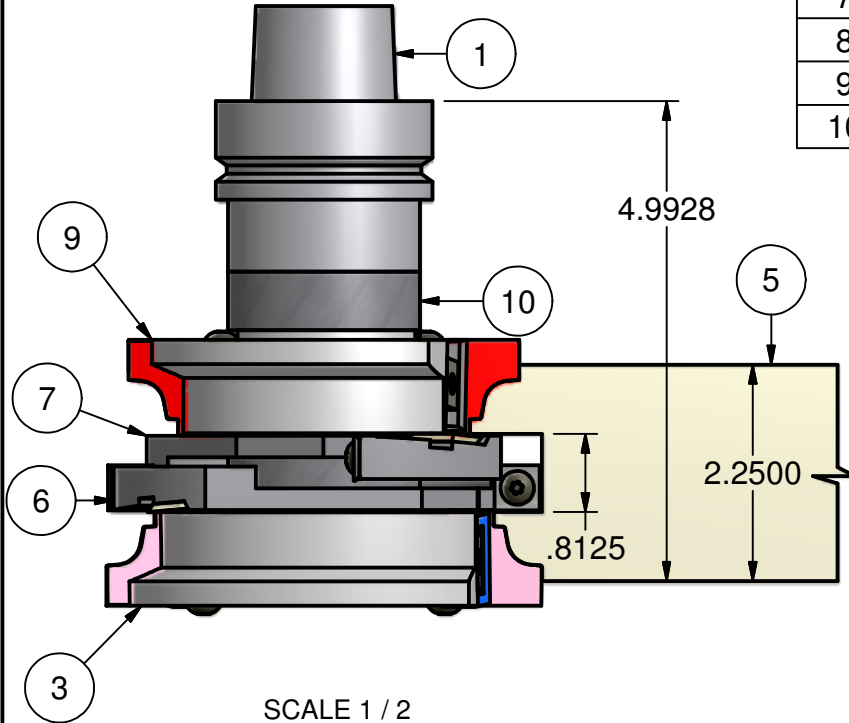

Parts List		
ITEM	QT	PART NUMBER
1	1	Lacey 1.250 toolholder
2	1	Lacey Toolholder Small Endcap
3	1	182-327 CW body E assembly
5	1	Stile B 2.25" wood
6	1	182-327 Groover body C assembly
7	1	182-327 Groover body B assembly
8	1	182-327 Groover spacer for 2.25 B
9	1	182-327 CW body A assembly
10	1	182-327 Top spacer for 2.25 B

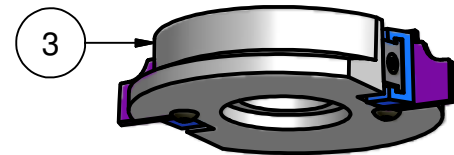
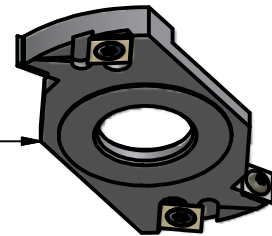
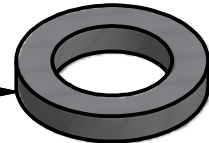
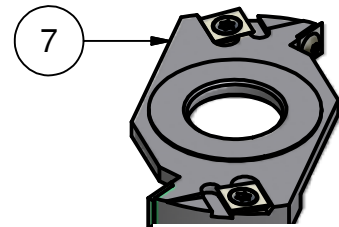
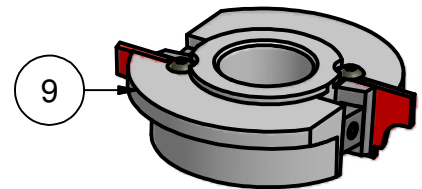

8 - between groovers

THIS DRAWING IS PROPERTY OF EW TOOLING, INC. AND MUST NOT BE USED IN ANY WAY DETRIMENTAL TO OUR INTERESTS

E.W. TOOLING, INC.
Cutting tools for the woodworking industry

PARTS LIST DRAWING

Originate: 12/09 Last edit: 12/14/09
 EW P/N: 182-327 Tips: Carbide inserts
 Cust P/N: Profile B for 2.25" wood

GEOMETRY
2 Wing(s)
10° Hook
5° Shear

The minor diameter is 3.792"

Setup for profile B 1.75" wood

1. Spacer .4158" thick
2. Body 338A with 50 x 12 x 1.5 indexable insert
3. Body 338B with insert 333
4. End cap

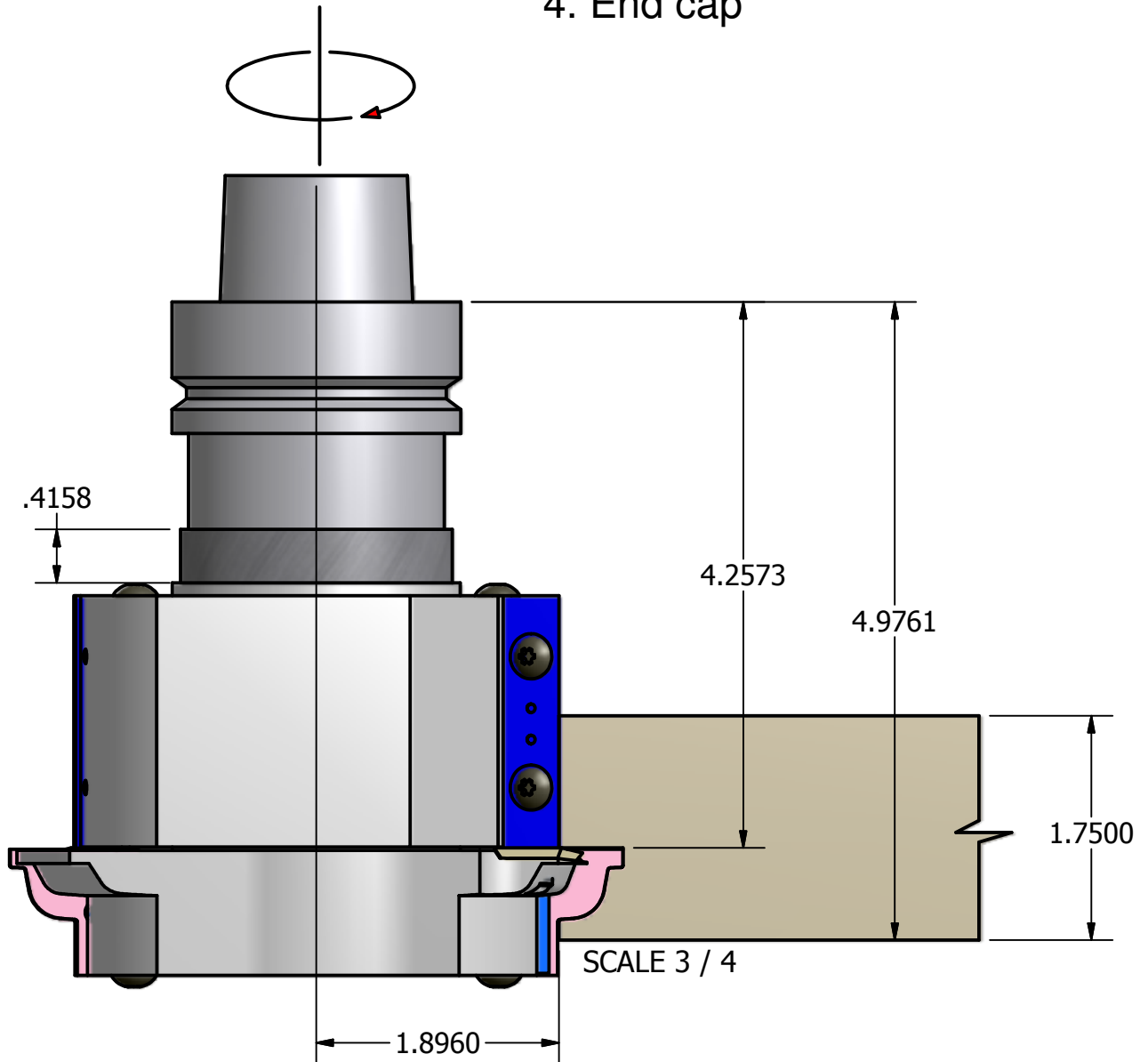

THIS DRAWING IS PROPERTY OF EW TOOLING, INC. AND MUST NOT BE USED IN ANY WAY DETRIMENTAL TO OUR INTERESTS

PARTS LIST DRAWING

E.W. TOOLING, INC.
Cutting tools for the woodworking industry

Originate: 12/09

Last edit: 12/14/09

EW P/N: 182-338

Tips: Carbide inserts

Cust P/N: Profile B for 1.75" wood

GEOMETRY
2 Wing(s)
10° Hook
5° Shear

Setup for profile B 1.75" wood

1. Spacer .4158" thick
2. Body 338A with 50 x 12 x 1.5 indexable insert
3. Body 338B with insert 333
4. End cap

The minor diameter is 3.792"

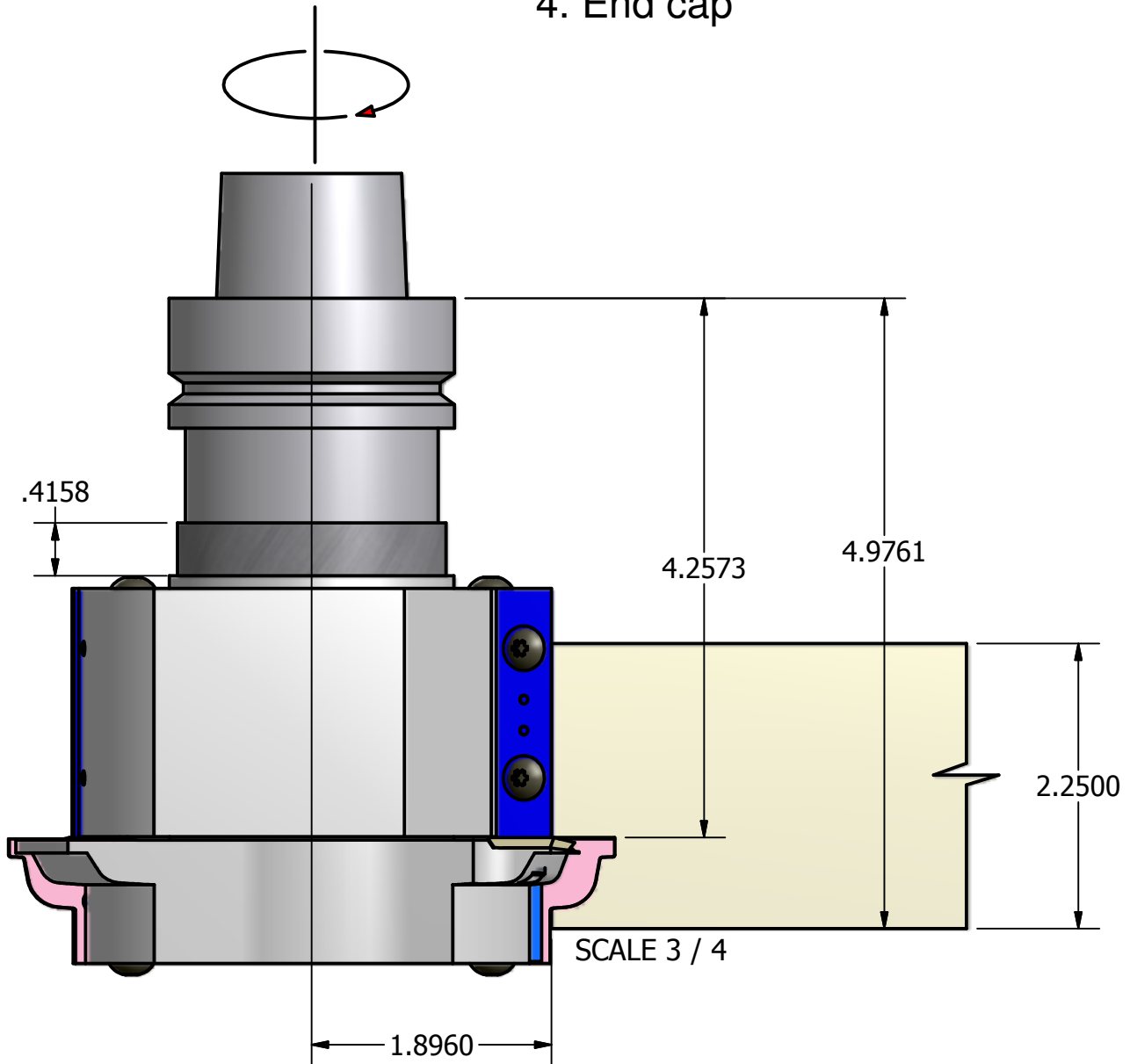

THIS DRAWING IS PROPERTY OF EW TOOLING, INC. AND MUST NOT BE USED IN ANY WAY DETRIMENTAL TO OUR INTERESTS

PARTS LIST DRAWING

E.W. TOOLING, INC.
Cutting tools for the woodworking industry

Originate: 12/09

Last edit: 12/14/09

EW P/N: 182-338

Tips: Carbide inserts

Cust P/N: Profile B for 2.25" wood