

Parts List		
ITEM	QTY	PART NUMBER
1	1	182-147 body
2	4	5Mx12.5M-BH-Torx
3	2	182-148 up insert
4	2	182-149 down insert
5	4	30x10 wedge with 10 face draft
6	8	.5 std clamp
7	8	.250-28 clamp screw

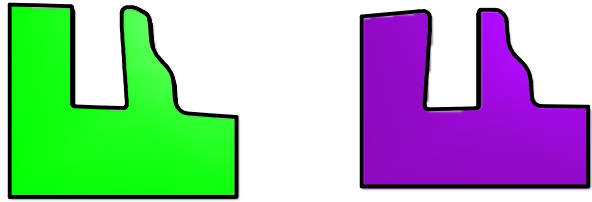

The upshear & downshear inserts **are not** interchangeable

GEOMETRY	
	3 Wing(s)
	10° Hook
	0° Shear
Minor Diameter	125mm
Major Diameter	150.2mm

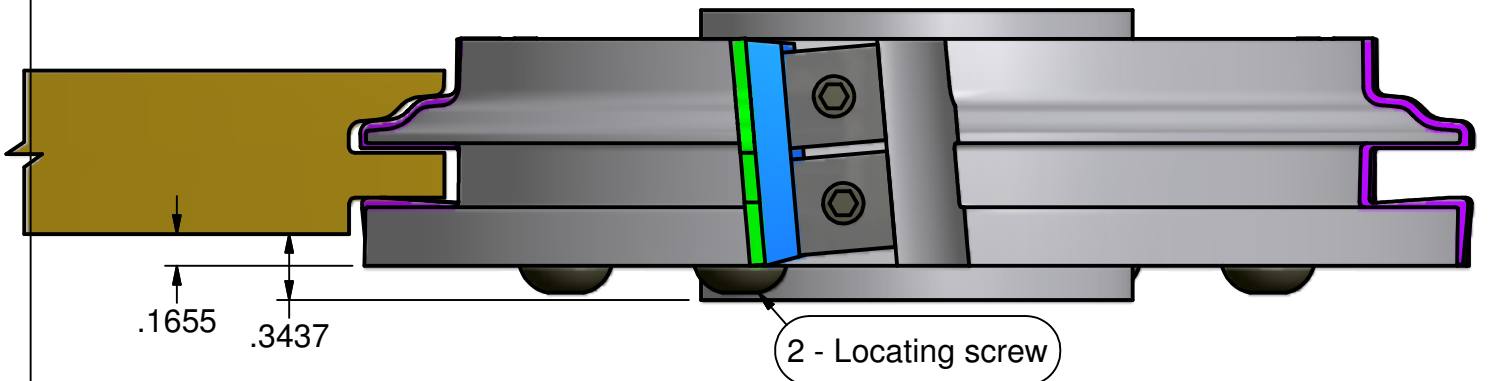
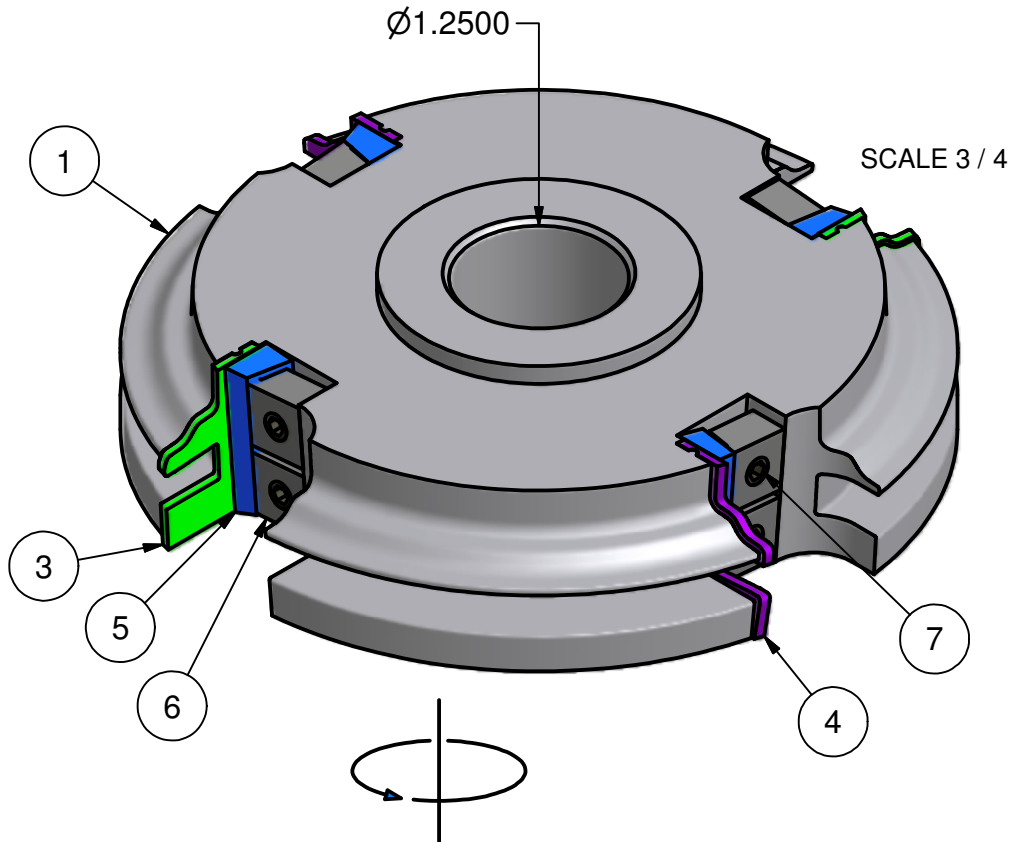

THIS DRAWING IS PROPERTY OF EW TOOLING, INC. AND MUST NOT BE USED IN ANY WAY DETRIMENTAL TO OUR INTERESTS

182

E.W. TOOLING, Inc.
Cutting tools for the woodworking industry

Approved by: _____

Originate: 2/3/09

Last edit: 2/3/09

EW P/N: 182-147 body Tips: 30 x 30.5 x 2mm Carbide Inserts

Cust P/N: #5 Santa Maria Cope profile - dedicated head