

Ø.6299 [16.0 mm]

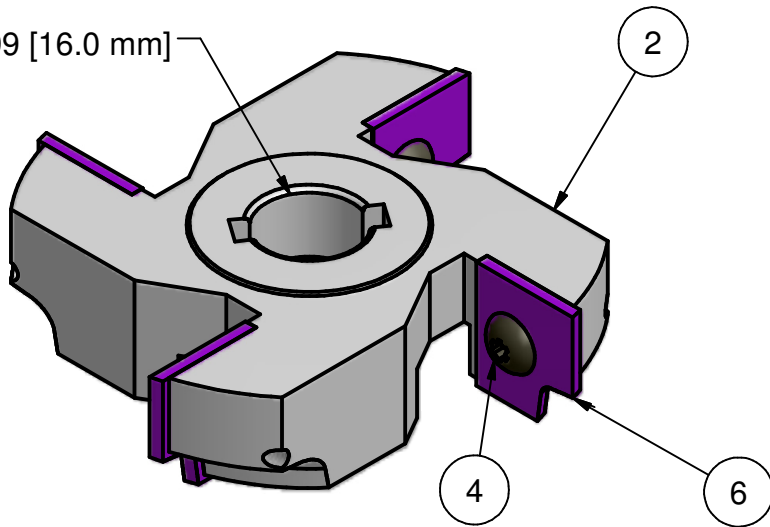

This view has the 2mm radius inserts

Parts List		
ITEM	QTY	PART NUMBER
2	1	182-385 body
3	4	182-386 R3mm insert
4	4	3.5 mm X 6mm BH
6	4	182-387 R2mm insert

Inserts need to be placed flush with the top edge of the body

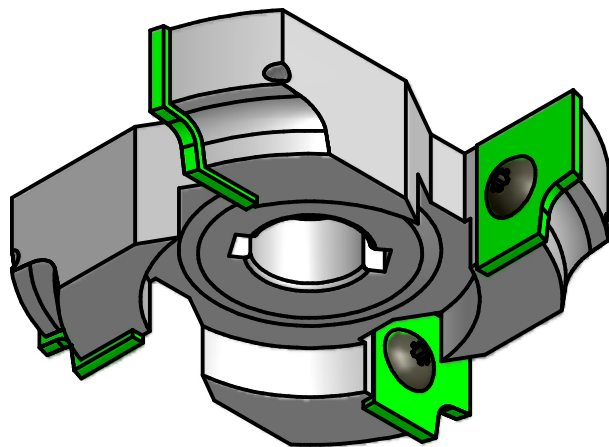
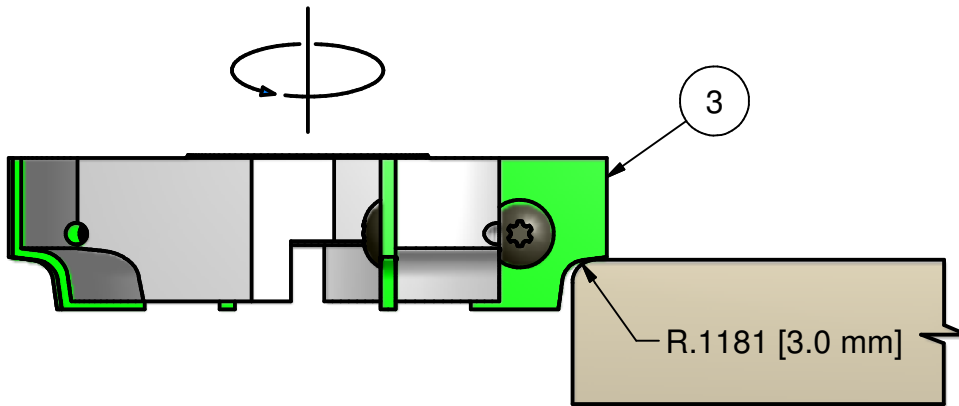

GEOMETRY	
	4 Wing(s)
	15° Hook
	0° Shear
Minor Diameter	2.759"
Major Diameter	3.197"

THIS DRAWING IS PROPERTY OF EW TOOLING, INC. AND MUST NOT BE USED IN ANY WAY DETRIMENTAL TO OUR INTERESTS

182 Hall Manufacturing Solutions

E.W. TOOLING, Inc.

Cutting tools for the woodworking industry

Approved by: _____

Originate: 5/4/10

Last edit: 5/7/10

EW P/N: 182-385

Tips: 20 X 20.5 X 2mm Carbide inserts

Cust P/N: