

Parts List		
ITEM	QTY	PART NUMBER
2	1	182-155 body
3	6	.5 std clamp
4	6	.250-28 clamp screw
5	3	5Mx12.5M-BH-Torx
6	3	182-157 backer
7	3	182-156 insert
9	3	182-159 backer
10	3	182-158 insert
12	3	30x15 Wedge With Holes
13	3	182-161 backer
14	3	182-160 insert
17	3	182-163 backer
18	3	182-162 insert

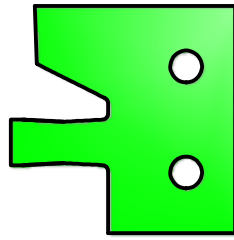

182-156 insert  
Uses 157 backer  
#1 Bevel profile

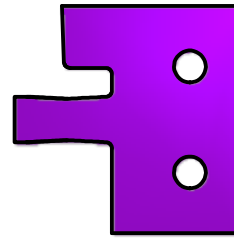

182-158 insert  
Uses 159 backer  
#2 Quarter Step profile

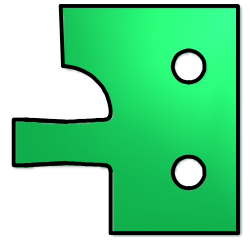

182-160 insert  
Uses 161 backer  
#6 Quarter Round Bead profile

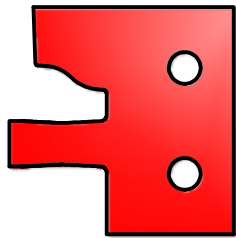

182-162 insert  
Uses 163 backer  
#7 CRP125 profile

GEOMETRY	
	3 Wing(s)
	10° Hook
	0° Shear
Minor Diameter	125mm
Major Diameter	150.4mm

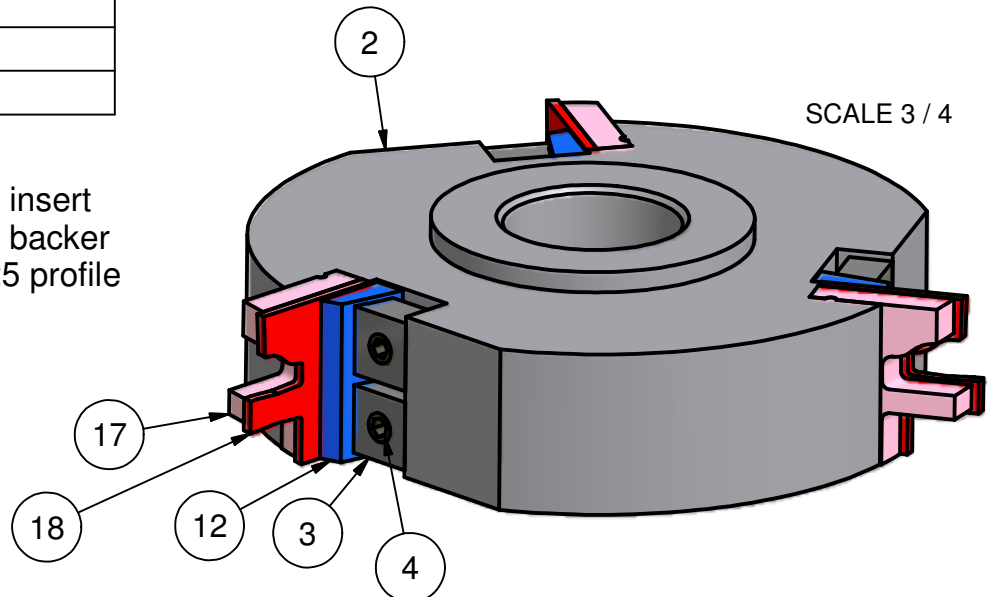

SCALE 3 / 4

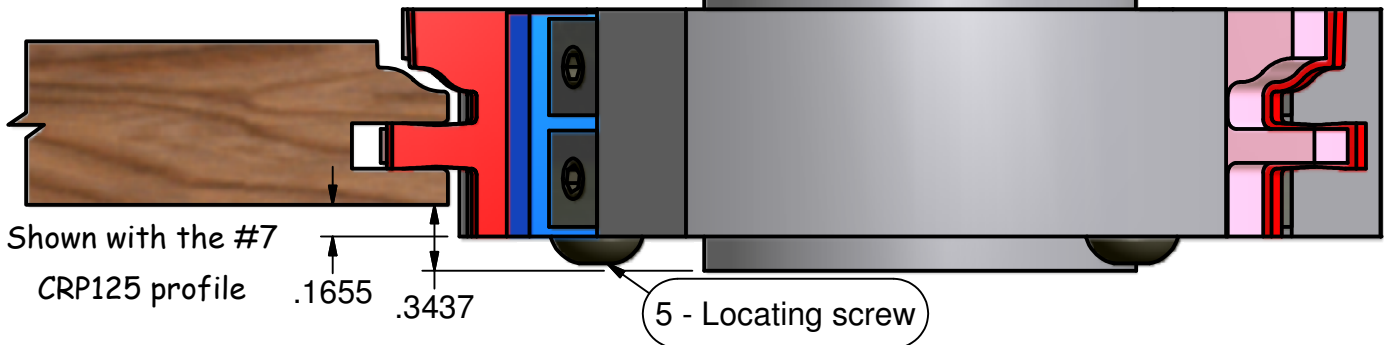

Shown with the #7  
CRP125 profile

.1655 .3437

5 - Locating screw

THIS DRAWING IS PROPERTY OF EW TOOLING, INC. AND MUST NOT BE USED IN ANY WAY DETRIMENTAL TO OUR INTERESTS

182-155

**E.W. TOOLING, Inc.**

Cutting tools for the woodworking industry

Approved by: \_\_\_\_\_

Originate: 2/3/09

Last edit: 2/3/09

EW P/N: 182-155 body Tips: 30 x 30.5 x 2mm Carbide Inserts

Cust P/N: Universal Head for multiple profiles