

TEETH: 3
 HOOK: 10°
 SHEAR: 0°
 TIPS: INSERT
 PA: N/A

MAX RPM: 10,000

DWG: 4-01-5866800

INSERT HEAD #: 4-01-5866800

PROFILE #: RNR

INSERT #: 4-10-5866801

BACKER #: 5-10-5866802

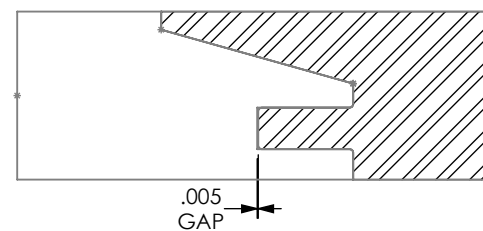
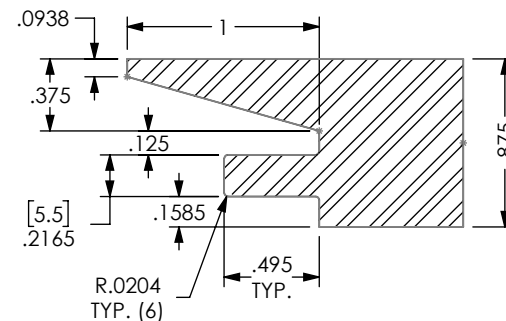
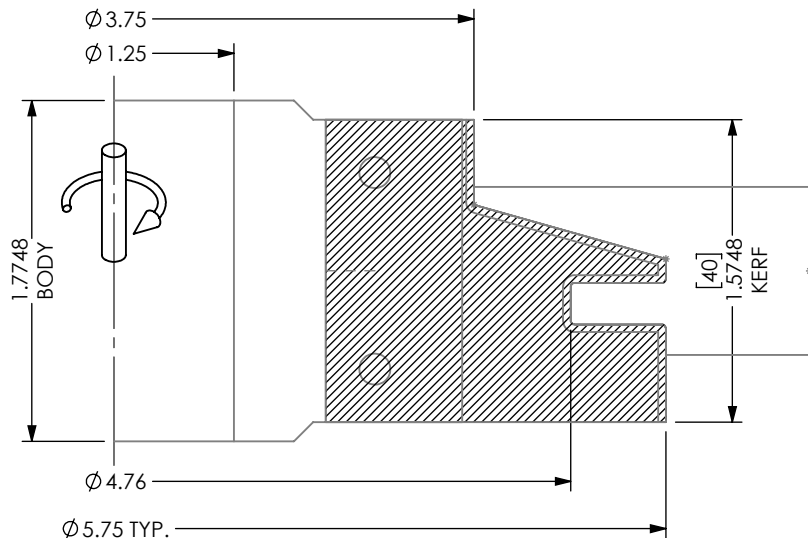

HALL MANUFACTURING DWG: 4-01-5866800

ATTN: _____ DATE: _____ PO#: _____

CUSTOM TOOLING MUST HAVE CUSTOMER APPROVAL PRIOR TO THE START OF MANUFACTURING. PLEASE REVIEW THIS DRAWING FOR ACCURACY, INCLUDING ROTATION, AND FAX A SIGNED AND DATED COPY. PRODUCTION WILL BEGIN UPON RECEIPT OF APPROVED DRAWING.

APPROVED BY: _____ DATE: _____

DATE:
8/20/24

DWN BY:
D.L.M.



REV.
+ SHEET 1 OF 3