

**TEETH: 3**  
**HOOK: 5°**  
**SHEAR: 15°**  
**TIPS: INSERT**  
**PA: N/A**

**MAX RPM: 9,000**

**DWG: 4-01-5704700**

**PROFILE #: P-3**

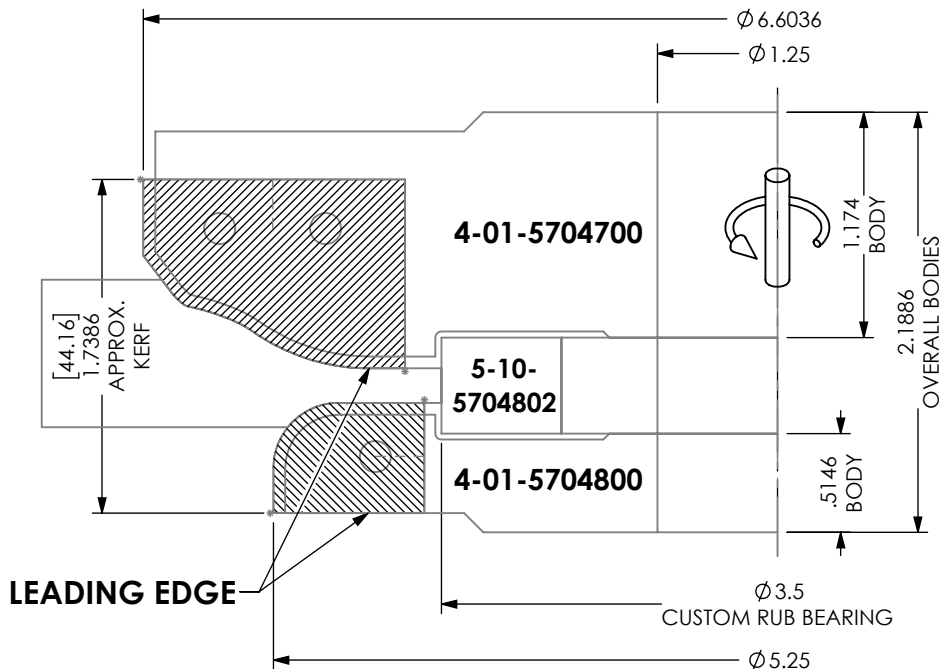
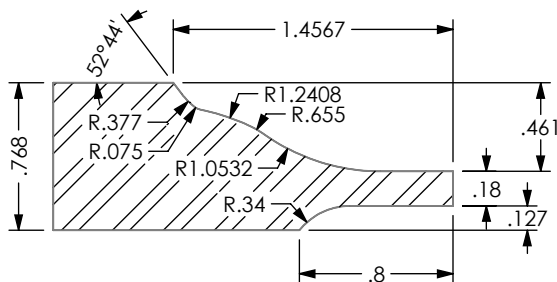

ATTN: \_\_\_\_\_ DATE: \_\_\_\_\_ PO#: \_\_\_\_\_

**CUSTOM TOOLING MUST HAVE CUSTOMER APPROVAL PRIOR TO THE START OF MANUFACTURING. PLEASE REVIEW THIS DRAWING FOR ACCURACY, INCLUDING ROTATION, AND FAX A SIGNED AND DATED COPY. PRODUCTION WILL BEGIN UPON RECEIPT OF APPROVED DRAWING.**

APPROVED BY: \_\_\_\_\_ DATE: \_\_\_\_\_

HALL MANUFACTURING DWG: 4-01-5704700

**DATE:**  
**10/4/23**

**DWN BY:**  
**D.L.M.**



REV. +  
 SHEET 1 OF 5