

**TEETH: 3**  
**HOOK: 20°**  
**SHEAR: 0°**  
**TIPS: INSERT**  
**PA: N/A**

**MAX RPM: 12,500**

**DWG: 4-01-5704400**

**A.K.A. #: P-10**

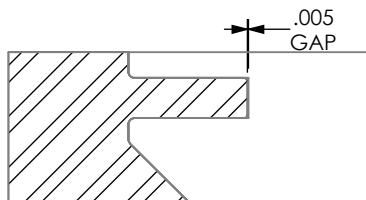
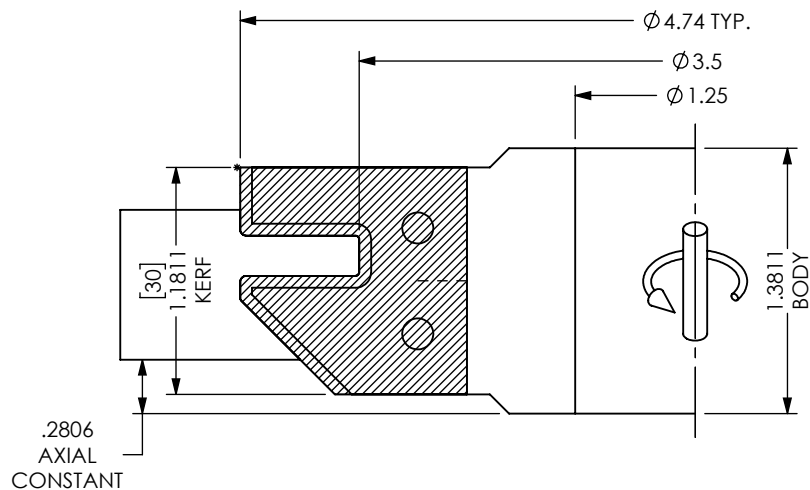
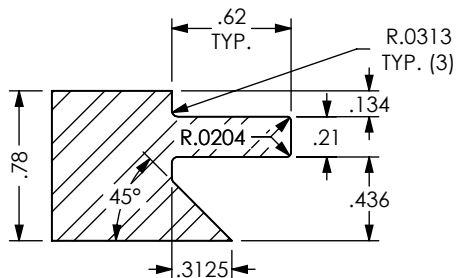

HALL MANUFACTURING DWG: 4-01-5704400

ATTN: \_\_\_\_\_ DATE: \_\_\_\_\_ PO#: \_\_\_\_\_

**CUSTOM TOOLING MUST HAVE CUSTOMER APPROVAL PRIOR TO THE START OF  
 MANUFACTURING. PLEASE REVIEW THIS DRAWING FOR ACCURACY, INCLUDING  
 ROTATION, AND FAX A SIGNED AND DATED COPY. PRODUCTION  
 WILL BEGIN UPON RECEIPT OF APPROVED DRAWING.**

APPROVED BY: \_\_\_\_\_ DATE: \_\_\_\_\_

**DATE:**  
**10/4/23**

**DWN BY:**  
**D.L.M.**



REV.  
 +

SHEET 1 OF 5