

TEETH: 3
HOOK: 20°
SHEAR: 0°
TIPS: INSERT
PA: N/A

MAX RPM: 12,500

DWG: 4-01-5704300

A.K.A. #: P-10

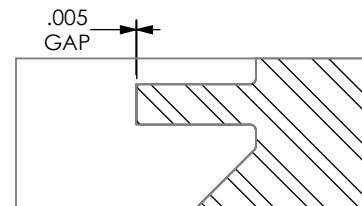
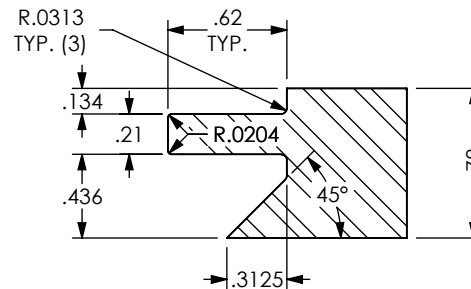
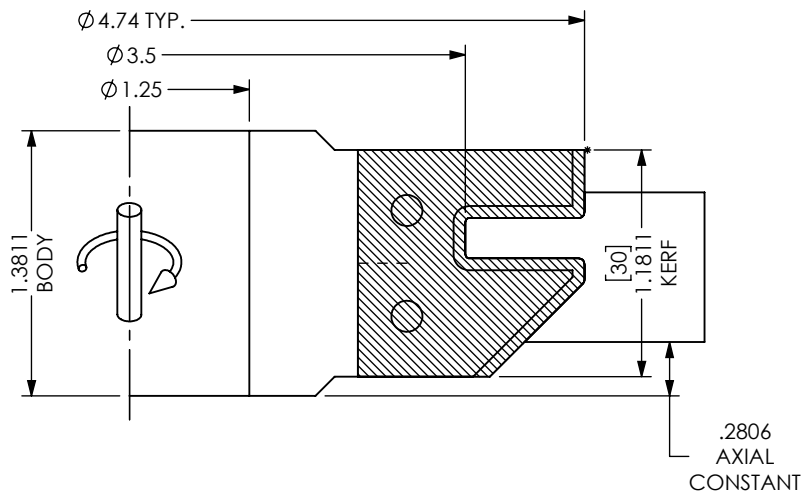

ATTN: _____ DATE: _____ PO#: _____

**CUSTOM TOOLING MUST HAVE CUSTOMER APPROVAL PRIOR TO THE START OF
 MANUFACTURING. PLEASE REVIEW THIS DRAWING FOR ACCURACY, INCLUDING
 ROTATION, AND FAX A SIGNED AND DATED COPY. PRODUCTION
 WILL BEGIN UPON RECEIPT OF APPROVED DRAWING.**

APPROVED BY: _____ DATE: _____

HALL MANUFACTURING DWG: 4-01-5704300

DATE:
10/4/23

DWN BY:
D.L.M.



REV.
 +

SHEET 1 OF 5