

**TEETH: 3**  
**HOOK: 10°**  
**SHEAR: 0°**  
**TIPS: INSERT**  
**PA: N/A**

**MAX RPM: 13,000**

**DWG: 4-01-4518800**

**CUTTER HEAD: #4-01-4518800**

**PROFILE #: SHANAHAN**

**INSERT: #4-10-4518807**

**BACKER: #5-10-4518808**

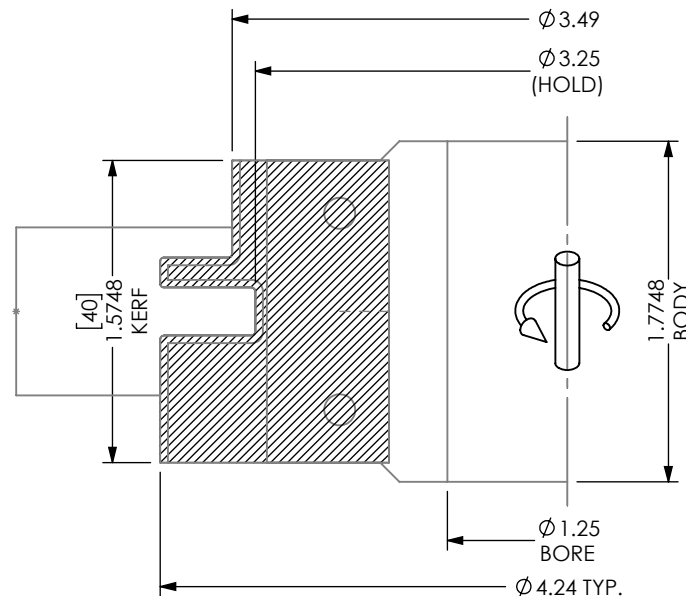
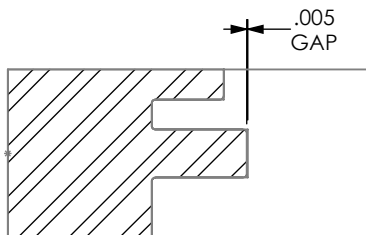
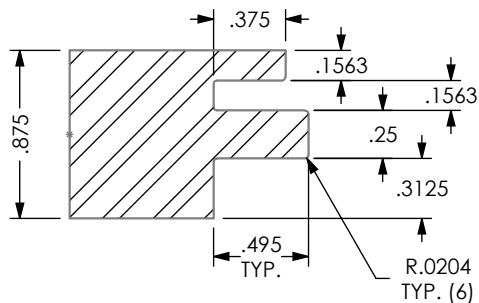

**HALL MANUFACTURING DWG: 4-01-4518800**

ATTN: \_\_\_\_\_ DATE: \_\_\_\_\_ PO#: \_\_\_\_\_

**CUSTOM TOOLING MUST HAVE CUSTOMER APPROVAL PRIOR TO THE START OF  
 MANUFACTURING. PLEASE REVIEW THIS DRAWING FOR ACCURACY, INCLUDING  
 ROTATION, AND FAX A SIGNED AND DATED COPY. PRODUCTION  
 WILL BEGIN UPON RECEIPT OF APPROVED DRAWING.**

APPROVED BY: \_\_\_\_\_ DATE: \_\_\_\_\_

**DATE:**  
**8/10/23**

**DWN BY:**  
**D.L.M.**



REV.  
 +

SHEET 4 OF 6