

TEETH: 3
HOOK: 10°
SHEAR: 0°
TIPS: INSERT
PA: N/A

MAX RPM: 13,000

DWG: 4-01-4518800

CUTTER HEAD: #4-01-4518800

PROFILE #: SHANAHAN

INSERT: #4-10-4518807

BACKER: #5-10-4518808

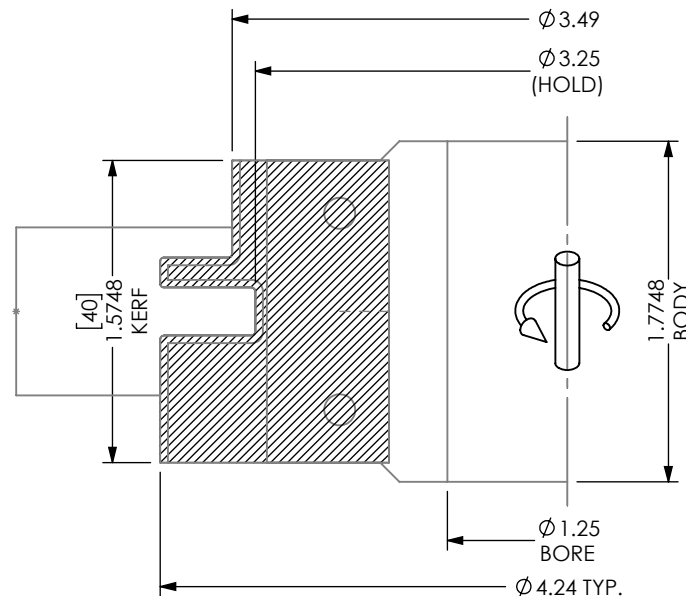
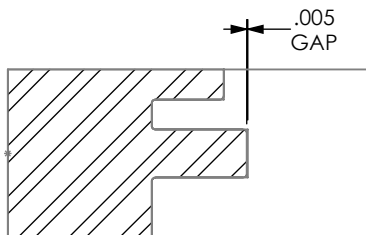
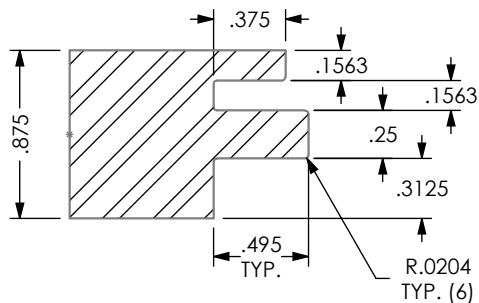

HALL MANUFACTURING DWG: 4-01-4518800

ATTN: _____ **DATE:** _____ **PO#:** _____

CUSTOM TOOLING MUST HAVE CUSTOMER APPROVAL PRIOR TO THE START OF MANUFACTURING. PLEASE REVIEW THIS DRAWING FOR ACCURACY, INCLUDING ROTATION, AND FAX A SIGNED AND DATED COPY. PRODUCTION WILL BEGIN UPON RECEIPT OF APPROVED DRAWING.

APPROVED BY: _____ **DATE:** _____

DATE:
8/10/23

DWN BY:
D.L.M.

REV.
+

SHEET 4 OF 6

