

TEETH: 3  
HOOK: 10°  
SHEAR: 0°  
TIPS: INSERT  
PA: N/A

MAX RPM: 9,500

DWG: 4-01-5260000

A.K.A. #: N/A

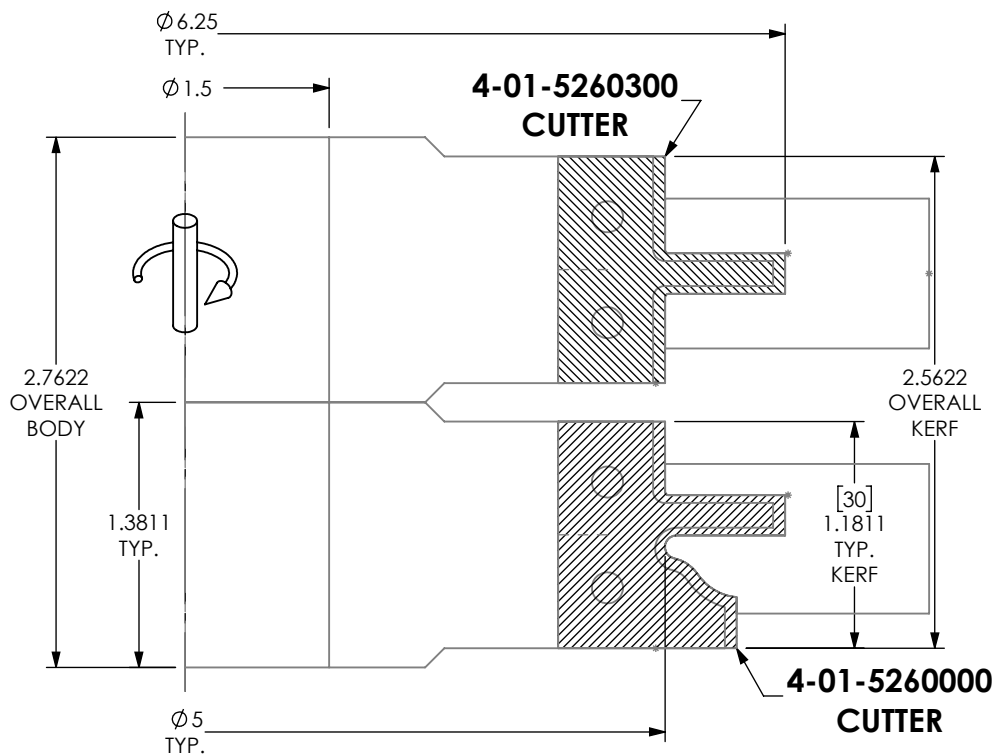

HALL MANUFACTURING DWG: 4-01-5260000

ATTN: \_\_\_\_\_ DATE: \_\_\_\_\_ PO#: \_\_\_\_\_

CUSTOM TOOLING MUST HAVE CUSTOMER APPROVAL PRIOR TO THE START OF  
MANUFACTURING. PLEASE REVIEW THIS DRAWING FOR ACCURACY, INCLUDING  
ROTATION, AND FAX A SIGNED AND DATED COPY. PRODUCTION  
WILL BEGIN UPON RECEIPT OF APPROVED DRAWING.

APPROVED BY: \_\_\_\_\_ DATE: \_\_\_\_\_

DATE:  
1/27/22

DWN BY:  
E.L.M.

REV.  
+

SHEET 2 OF 5

