

TEETH: N/A  
HOOK: 15°  
SHEAR: N/A  
TIPS: INSERT  
PA: N/A

MAX RPM: N/A

DWG: 4-10-5243501

A.K.A. #: RCP22I

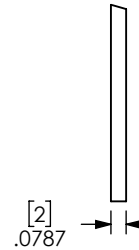
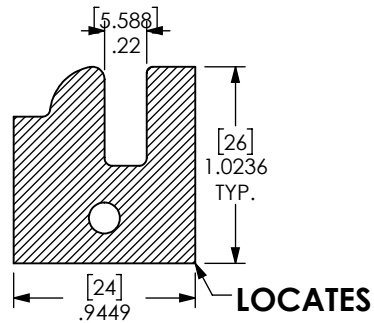

HALL MANUFACTURING DWG: 4-10-5243501

ATTN: \_\_\_\_\_ DATE: \_\_\_\_\_ PO#: \_\_\_\_\_

CUSTOM TOOLING MUST HAVE CUSTOMER APPROVAL PRIOR TO THE START OF MANUFACTURING. PLEASE REVIEW THIS DRAWING FOR ACCURACY, INCLUDING ROTATION, AND FAX A SIGNED AND DATED COPY. PRODUCTION WILL BEGIN UPON RECEIPT OF APPROVED DRAWING.

APPROVED BY: \_\_\_\_\_ DATE: \_\_\_\_\_

DATE:  
12/27/21

DWN BY:  
E.L.M.

REV.  
+

SHEET 1 OF 2

