

TEETH: 3
 HOOK: 10°
 SHEAR: 0°
 TIPS: INSERT
 PA: N/A

MAX RPM: 13,000

DWG: 4-01-5180700

A.K.A. #: N/A

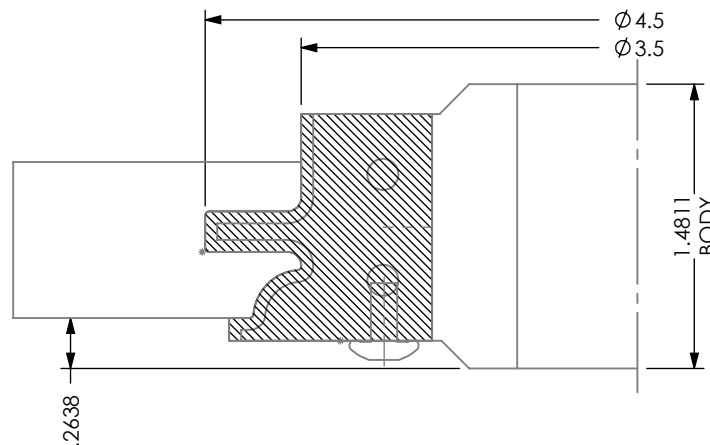
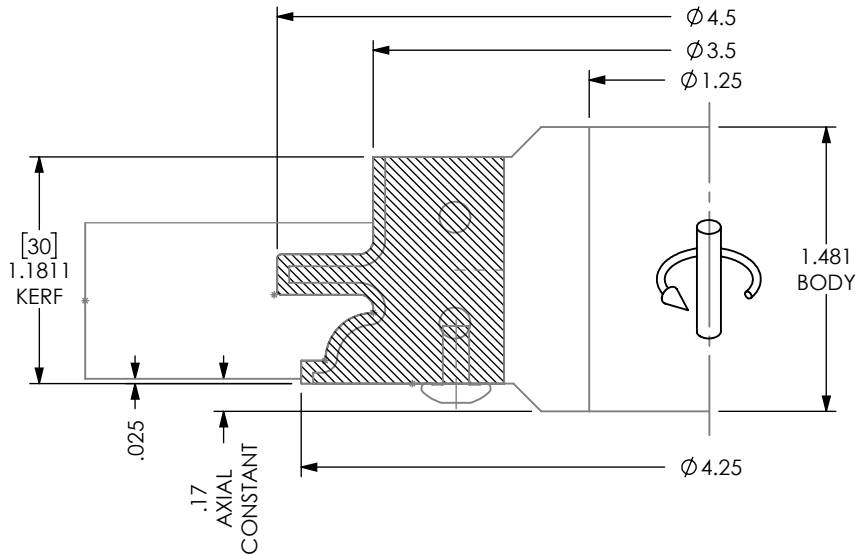
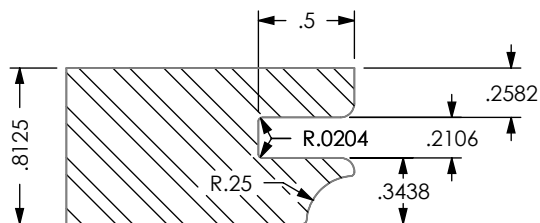
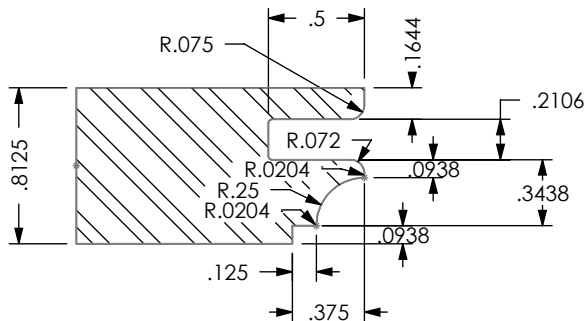

HALL MANUFACTURING DWG: 4-01-5180700

ATTN: _____ DATE: _____ PO#: _____

CUSTOM TOOLING MUST HAVE CUSTOMER APPROVAL PRIOR TO THE START OF MANUFACTURING. PLEASE REVIEW THIS DRAWING FOR ACCURACY, INCLUDING ROTATION, AND FAX A SIGNED AND DATED COPY. PRODUCTION WILL BEGIN UPON RECEIPT OF APPROVED DRAWING.

APPROVED BY: _____ DATE: _____

DATE:
10/8/21

DWN BY:
G.R.F.

REV.
+

SHEET 1 OF 3

