

TEETH: 3 EFF.
HOOK: 5°
SHEAR: 15° ON PROFILED, 44° ON STRAIGHT
TIPS: PCD
PA: 75.72mm

MAX RPM: 22,000

DWG: 1-03-4744500

PROFILED SHANK ROUTER: #1-03-4744501
STRAIGHT CUTTER: #1-02-4746000

PROFILE #: E11

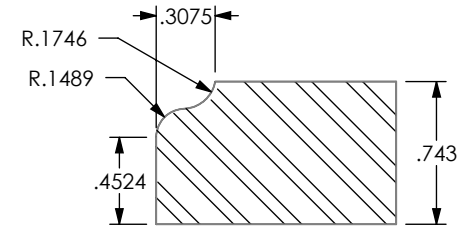
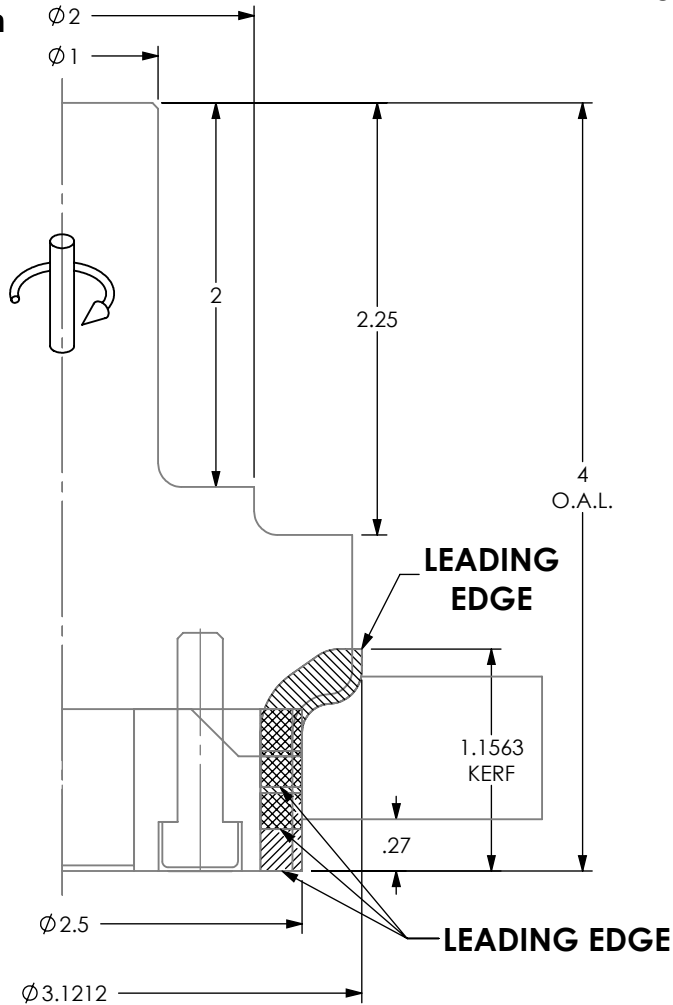

HALL MANUFACTURING DWG: 1-03-4744500

ATTN: _____ DATE: _____ PO#: _____

CUSTOM TOOLING MUST HAVE CUSTOMER APPROVAL PRIOR TO THE START OF MANUFACTURING. PLEASE REVIEW THIS DRAWING FOR ACCURACY, INCLUDING ROTATION, AND FAX A SIGNED AND DATED COPY. PRODUCTION WILL BEGIN UPON RECEIPT OF APPROVED DRAWING.

APPROVED BY: _____ DATE: _____

DATE:
9/20/21

DWN BY:
D.L.M.

REV.
02

SHEET 1 OF 3

