

**TEETH: 3**  
**HOOK: 15.109°**  
**SHEAR: 0°**  
**TIPS: INSERT**  
**PA: N/A**

**MAX RPM: 12,000**

**DWG: 4-01-5053300**

**A.K.A. #: RCP291C**

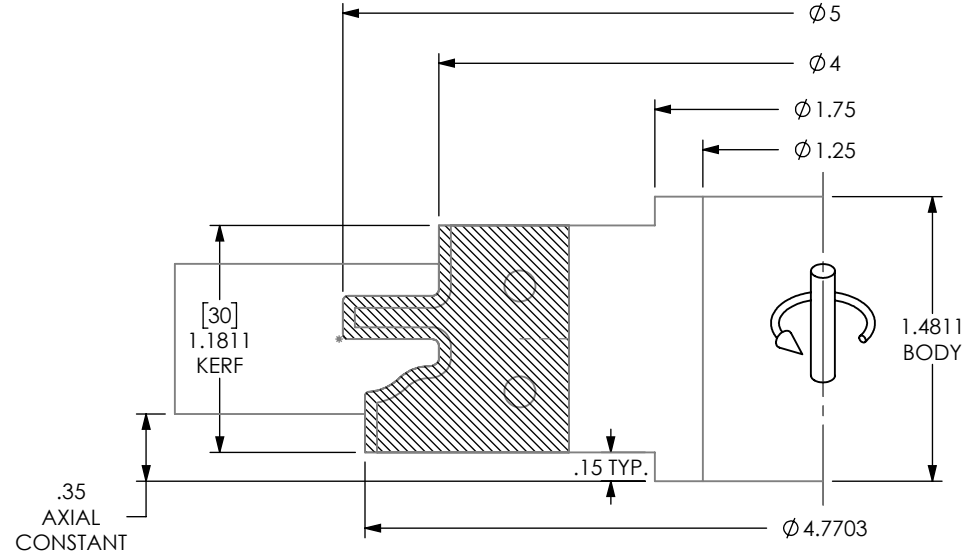
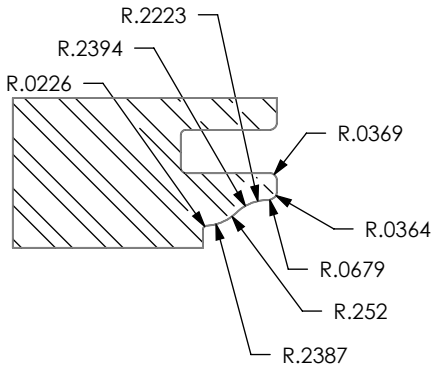
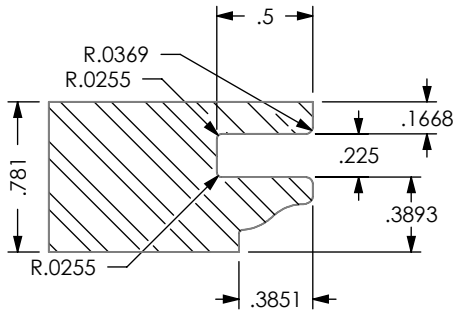

**HALL MANUFACTURING DWG: 4-01-5053300**

ATTN: \_\_\_\_\_ DATE: \_\_\_\_\_ PO#: \_\_\_\_\_

**CUSTOM TOOLING MUST HAVE CUSTOMER APPROVAL PRIOR TO THE START OF  
 MANUFACTURING. PLEASE REVIEW THIS DRAWING FOR ACCURACY, INCLUDING  
 ROTATION, AND FAX A SIGNED AND DATED COPY. PRODUCTION  
 WILL BEGIN UPON RECEIPT OF APPROVED DRAWING.**

APPROVED BY: \_\_\_\_\_ DATE: \_\_\_\_\_

**DATE:**  
**5/26/21**

**DWN BY:**  
**D.L.M.**

REV.  
 +

SHEET 1 OF 5

