

TEETH: 3
 HOOK: 15.825°
 SHEAR: 0°
 TIPS: INSERT
 PA: N/A

MAX RPM: 12,000

DWG: 4-01-4440800

NEW INSERT HEAD #: 4-01-4440800
 EXISTING INSERT #: 4-10-4440801

A.K.A. #: RCP31IC

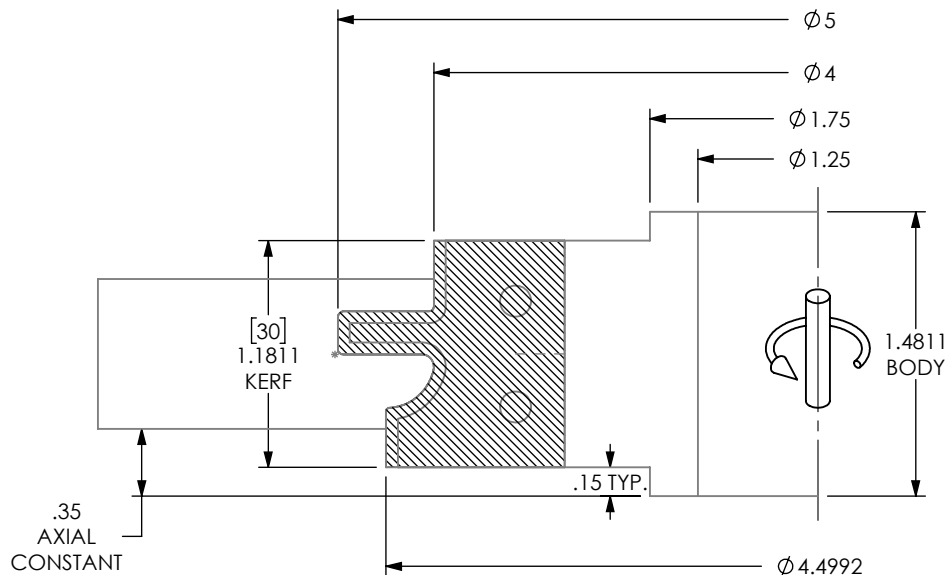
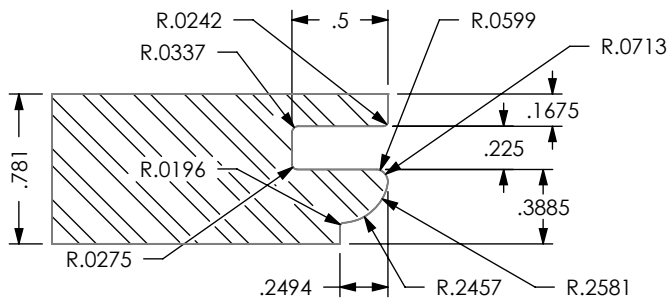

HALL MANUFACTURING DWG: 4-01-4440800

ATTN: _____ DATE: _____ PO#: _____

CUSTOM TOOLING MUST HAVE CUSTOMER APPROVAL PRIOR TO THE START OF MANUFACTURING. PLEASE REVIEW THIS DRAWING FOR ACCURACY, INCLUDING ROTATION, AND FAX A SIGNED AND DATED COPY. PRODUCTION WILL BEGIN UPON RECEIPT OF APPROVED DRAWING.

APPROVED BY: _____ DATE: _____

DATE:
5/26/21

DWN BY:
D.L.M.



REV.
+

SHEET 1 OF 5