

TEETH: 3  
 HOOK: 15.825°  
 SHEAR: 0°  
 TIPS: INSERT  
 PA: N/A

MAX RPM: 12,000

DWG: 4-01-4440800

NEW INSERT HEAD #: 4-01-4440800  
 EXISTING INSERT #: 4-10-4440801

A.K.A. #: RCP31IC

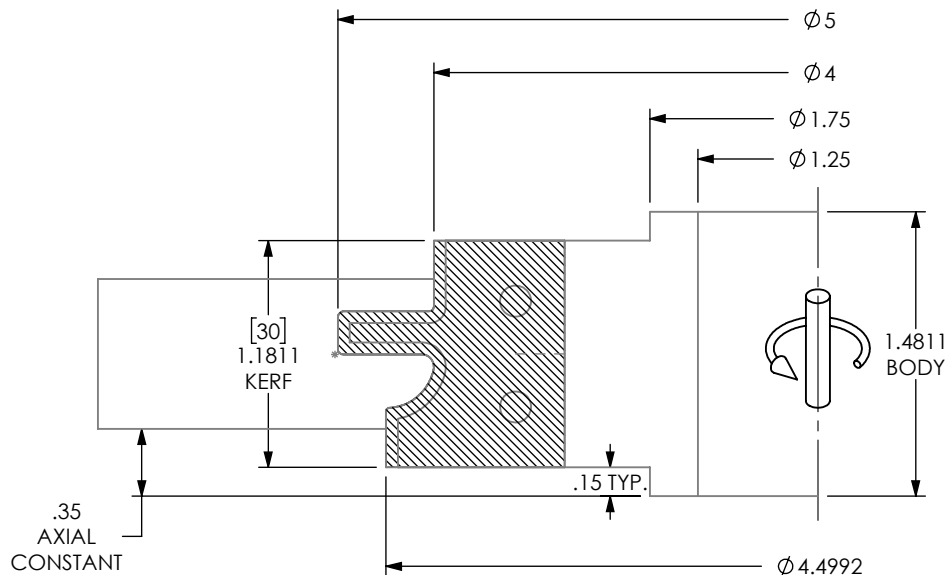
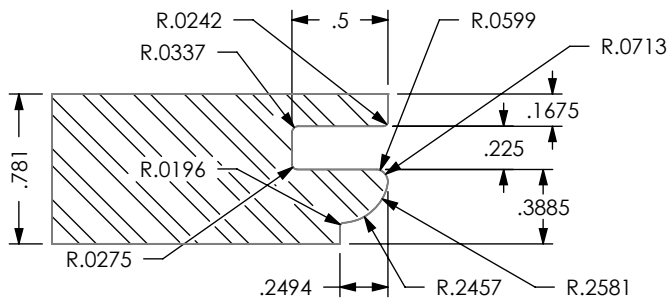

HALL MANUFACTURING DWG: 4-01-4440800

ATTN: \_\_\_\_\_ DATE: \_\_\_\_\_ PO#: \_\_\_\_\_

CUSTOM TOOLING MUST HAVE CUSTOMER APPROVAL PRIOR TO THE START OF  
 MANUFACTURING. PLEASE REVIEW THIS DRAWING FOR ACCURACY, INCLUDING  
 ROTATION, AND FAX A SIGNED AND DATED COPY. PRODUCTION  
 WILL BEGIN UPON RECEIPT OF APPROVED DRAWING.

APPROVED BY: \_\_\_\_\_ DATE: \_\_\_\_\_

DATE:  
5/26/21

DWN BY:  
D.L.M.



REV.  
+ SHEET 1 OF 5