

TEETH: 2  
 HOOK: 10°  
 SHEAR: 0°  
 TIPS: INSERT  
 PA: N/A

MAX RPM: 24,000

DWG: 4-03-5053500

A.K.A. #: N/A

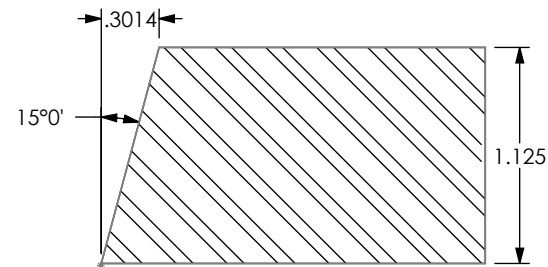
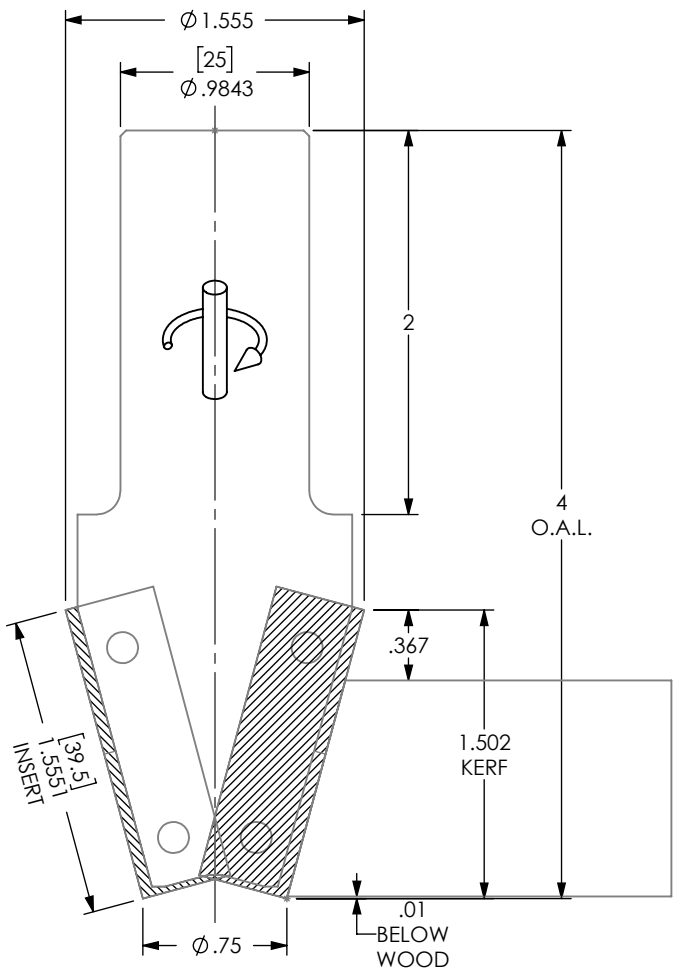

ATTN: \_\_\_\_\_ DATE: \_\_\_\_\_ PO#: \_\_\_\_\_

CUSTOM TOOLING MUST HAVE CUSTOMER APPROVAL PRIOR TO THE START OF MANUFACTURING. PLEASE REVIEW THIS DRAWING FOR ACCURACY, INCLUDING ROTATION, AND FAX A SIGNED AND DATED COPY. PRODUCTION WILL BEGIN UPON RECEIPT OF APPROVED DRAWING.

APPROVED BY: \_\_\_\_\_ DATE: \_\_\_\_\_

HALL MANUFACTURING DWG: 4-03-5053500

DATE:  
4/21/21

DWN BY:  
E.L.M.



REV.	
+	SHEET 1 OF 4