

TEETH: 2  
HOOK: 10°  
SHEAR: 0°  
TIPS: INSERT  
PA: N/A

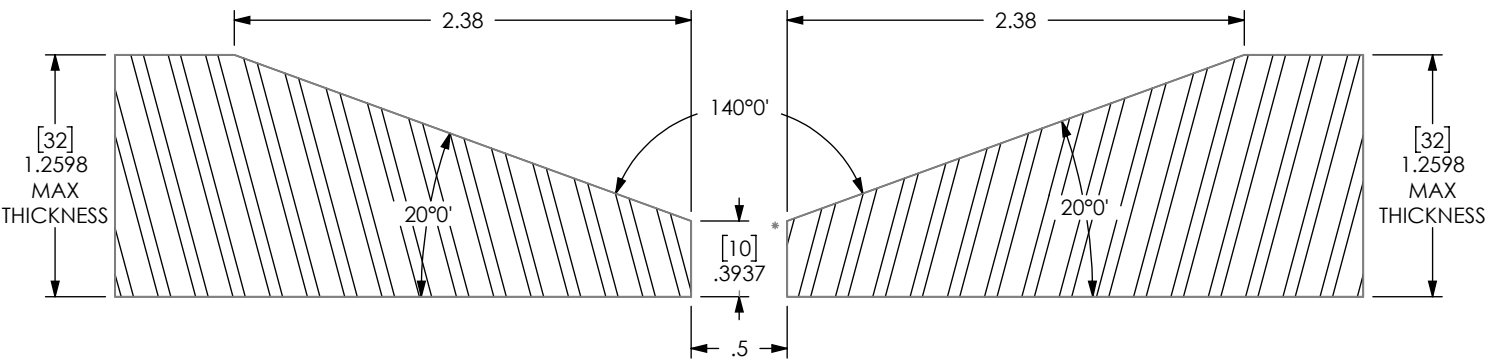
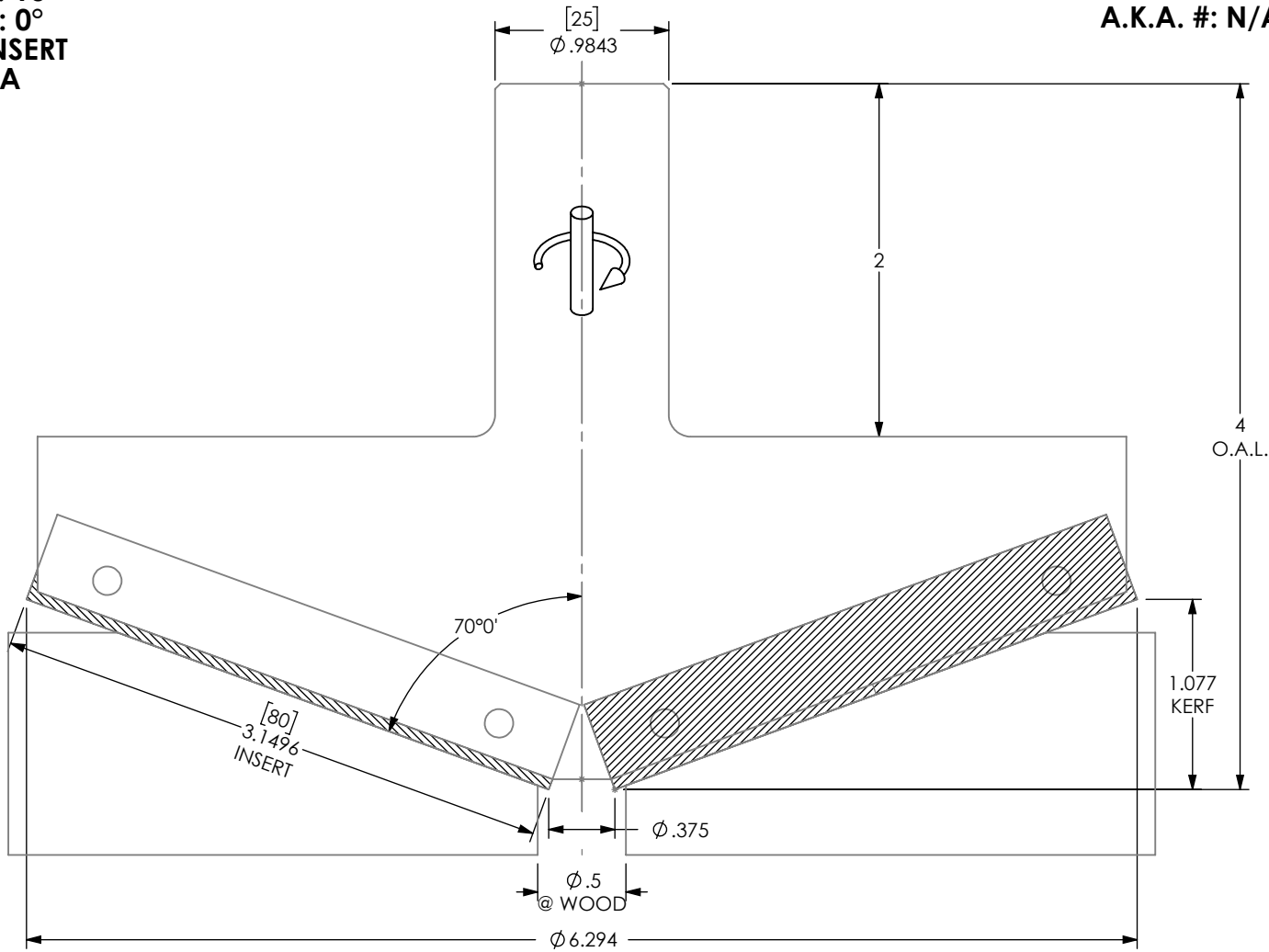

ATTN: \_\_\_\_\_

DATE: \_\_\_\_\_ PO#: \_\_\_\_\_

CUSTOM TOOLING MUST HAVE CUSTOMER APPROVAL PRIOR TO THE START OF MANUFACTURING. PLEASE REVIEW THIS DRAWING FOR ACCURACY, INCLUDING ROTATION, AND FAX A SIGNED AND DATED COPY TO 740-498-5454. PRODUCTION WILL BEGIN UPON RECEIPT OF APPROVED DRAWING.

APPROVED BY: \_\_\_\_\_ DATE: \_\_\_\_\_

CUSTOMER: HALL MANUFACTURING

DATE:  
4/21/21

DWN BY:  
E.L.M.

REV.  
+

SHEET 1 OF 4

