

MAX RPM: 21,000

PROFILE #: E3

TEETH: 3 EFF.
 HOOK: 5°
 SHEAR: 15° ON PROFILED, 44° ON STRAIGHT
 TIPS: PCD
 PA: 75.0mm

PROFILED SHANK ROUTER: #1-03-4744301
 STRAIGHT CUTTER: #1-02-4746000

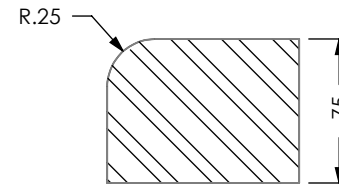
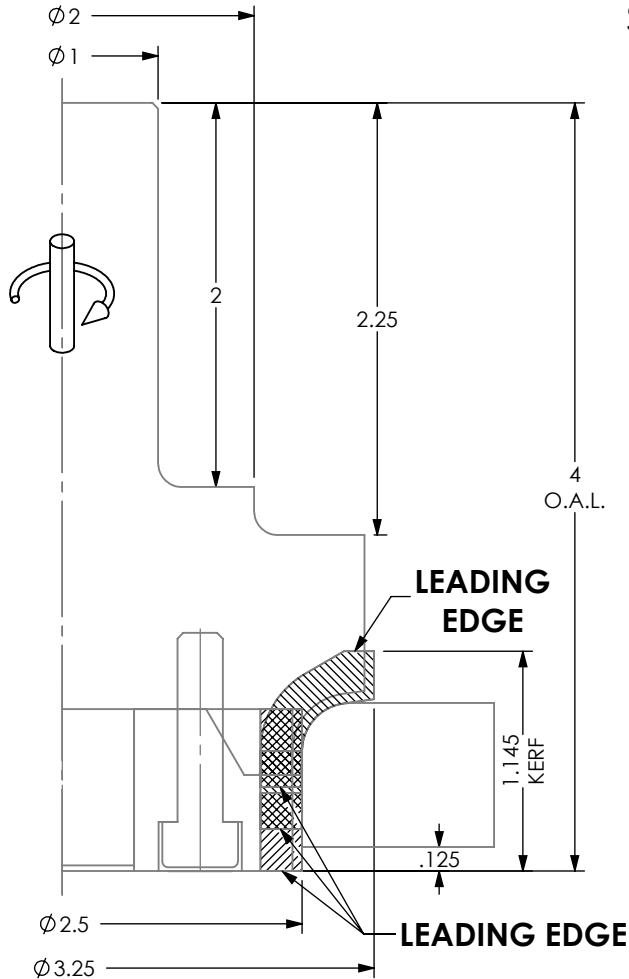

HALL MANUFACTURING DWG: 1-03-4744300

ATTN: _____ DATE: _____ PO#: _____

CUSTOM TOOLING MUST HAVE CUSTOMER APPROVAL PRIOR TO THE START OF MANUFACTURING. PLEASE REVIEW THIS DRAWING FOR ACCURACY, INCLUDING ROTATION, AND FAX A SIGNED AND DATED COPY. PRODUCTION WILL BEGIN UPON RECEIPT OF APPROVED DRAWING.

APPROVED BY: _____ DATE: _____

DATE:
5/17/21

DWN BY:
D.L.M.



REV.
02

SHEET 2 OF 4