



# 663



ORDER NO.	D		I	L	Z	S
Right-hand rotation	inches	mm	mm	mm		mm
<b>663.005.11</b>	1-1/2	38	12	60	3	12x35
<b>663.004.11</b>	2-3/8	60	12	80	3	12x50
<b>663.003.11</b>	3-5/32	80	12	90	3	20x50
<b>new 663.006.11</b>	3-15/16	100	12	90	4	20x50

### Spare parts

790.120.03	990.075.00
790.120.03	990.075.00
790.120.03	990.075.00
790.120.03	990.075.00

- Spare parts**
- 991.061.00 T15 Torx key
  - 990.036.00 M8x25mm TE screw
  - 990.020.00 Hex nut for threaded arbors M8

The screw 990.036.00 and the nut 990.020.00 (on the shank) only fit item 663.003.11

### TECHNICAL DETAILS:

- Super strength steel.
- 3, 4 cutting edges [Z3/Z4].

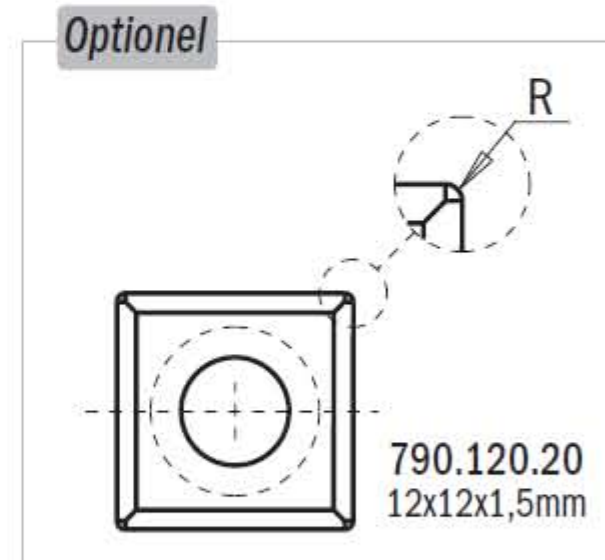
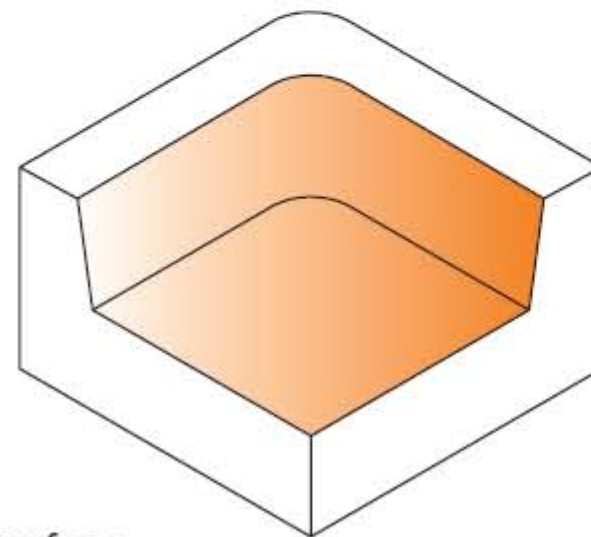

Drawings are 1:2 scale

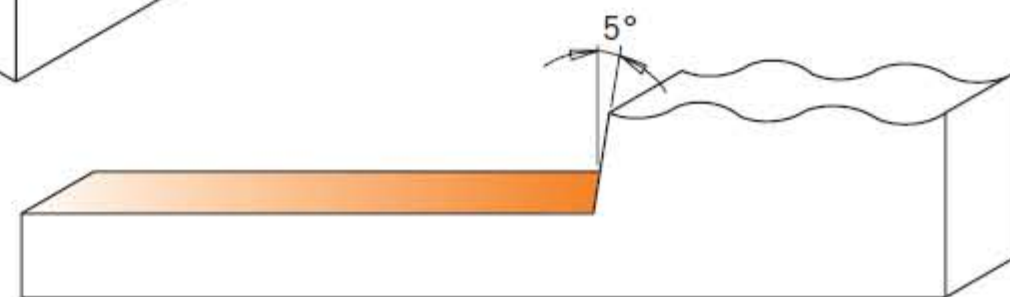

### APPLICATION:

the new router bit for CNC routers is ideal for fast removal of material over a large surface area leaving an improved finish at the bottom of the cut. Used on soft and hardwood, particle board and MDF. The cutter uses 4-sided inserts in super micrograin carbide.

A cost effective solution compared to brazed router bits and solid carbide spiral bits.