

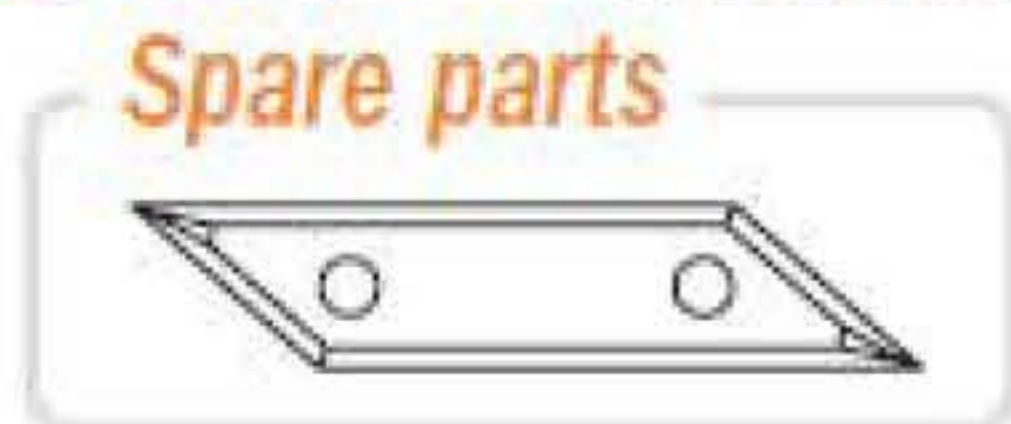

# 663.1

**INSERT CARBIDE** **MEC** **Z1** **Z2** **RH** **2X LONGER LIFE**

ORDER NO. Right-hand rotation	D		A	I mm	L mm	Z	S mm	Spare parts
	inches	mm						
663.103.11	1-3/8	35	45°	42	125	1	20x50	790.580.01
663.102.11	1-21/32	42	60°	35	115	1	20x50	790.580.01
663.101.11	2-3/64	52	91°	25	102	1	20x50	790.360.01
663.110.11	2-3/8	60	110°	21	95	1	20x60	790.360.01
663.120.11	3-27/64	87	120°	24	95	2	20x50	790.496.01
663.130.11	3-37/64	91	130°	20.2	95	2	20x50	790.496.01
663.150.11	3-51/64	96.5	150°	12.4	95	2	20x50	790.496.01



- Spare parts**
- 990.073.00 M3,5x5x7,2mm Torx T15 screw (for 790.580.01)
  - 990.075.00 M4x6x8,2mm Torx T15 screw
  - 991.061.00 Torx key T15
  - 990.036.00 M8x25mm TE screw
  - 990.020.00 Hex nut for threaded arbors M8

**Optional** S790.360.03 Knives 36x12x1.5mm  
(Super Micrograin for chipboard, MDF and HDF)

### CORRECT KNIFE POSITIONING

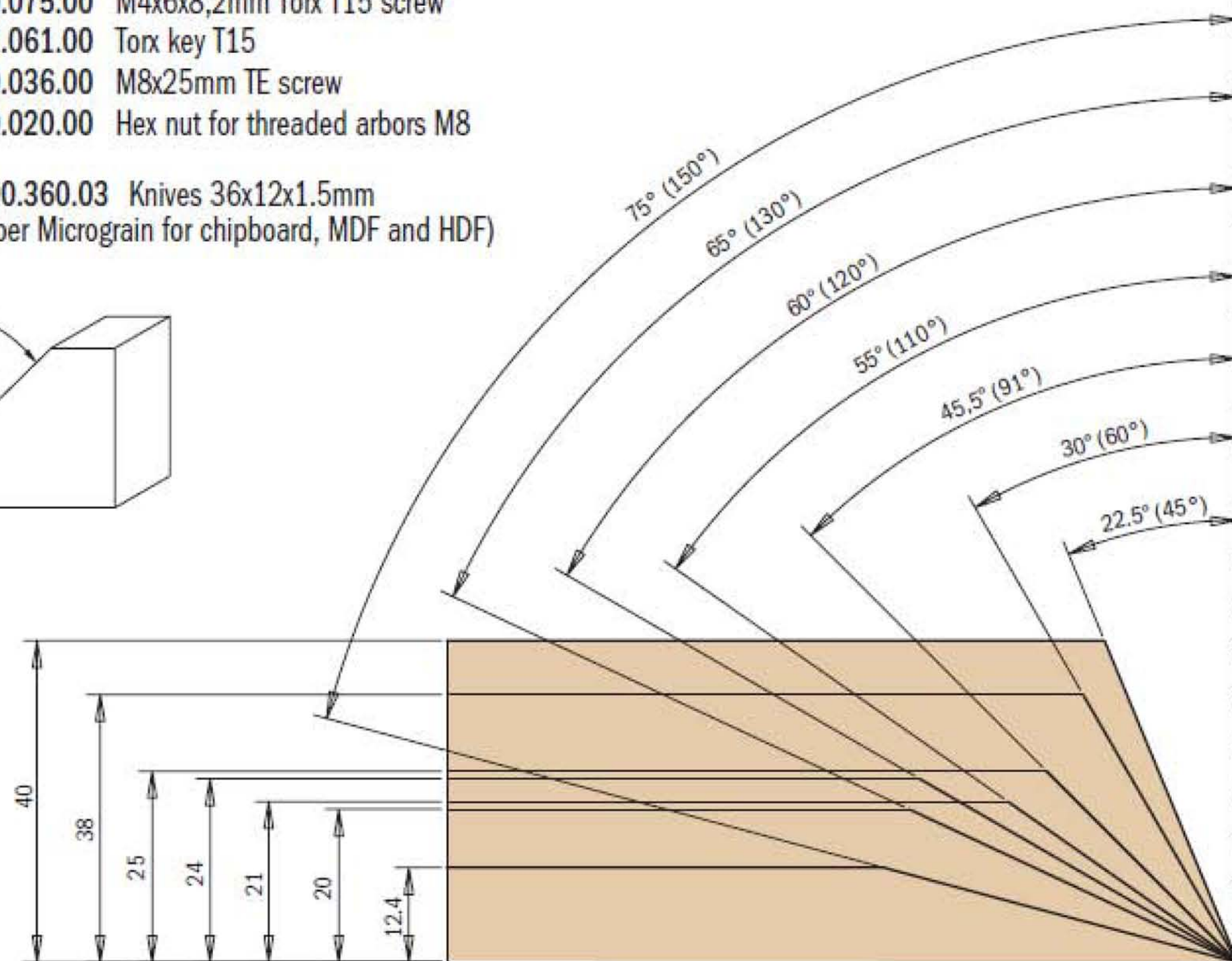
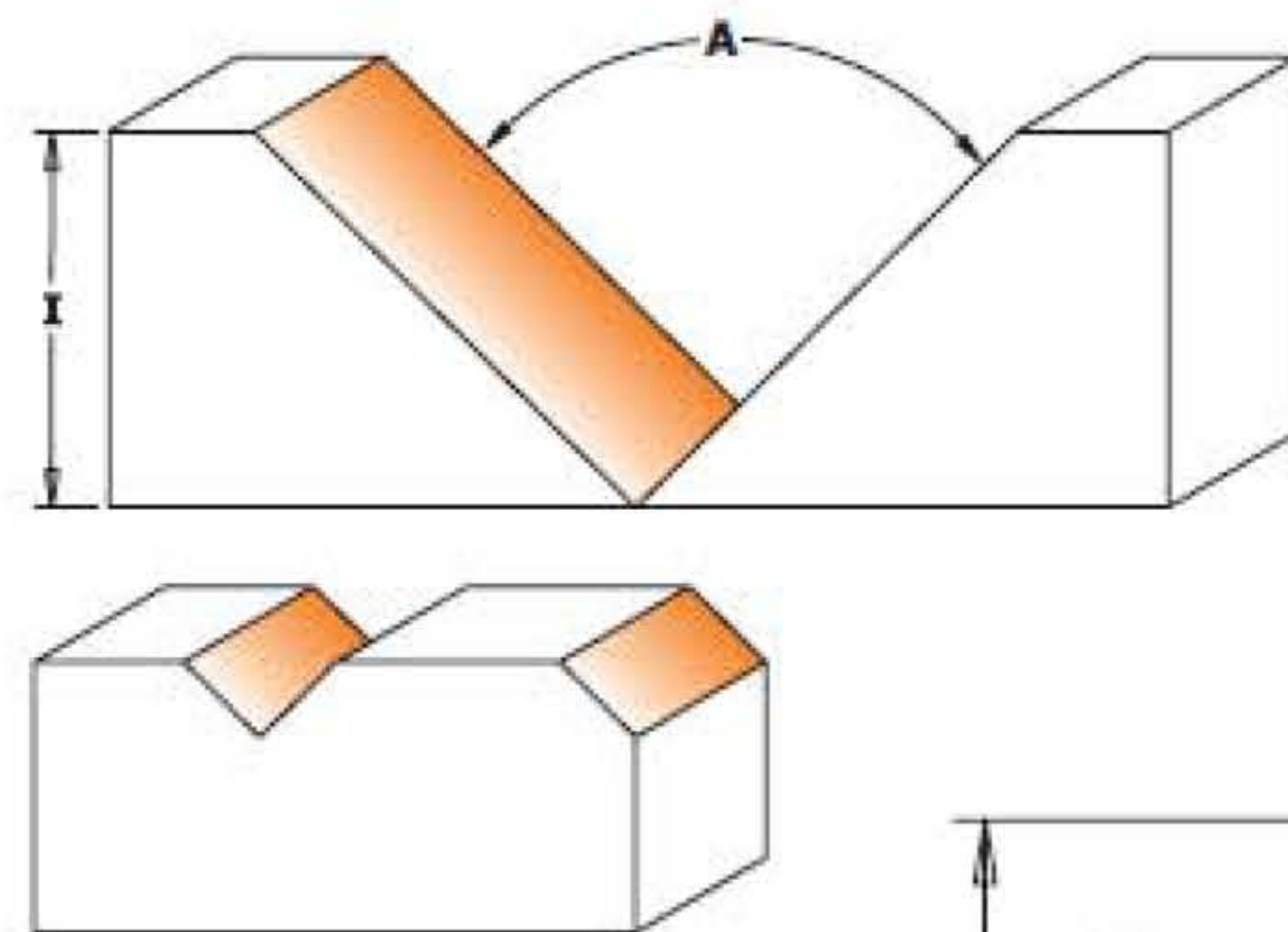
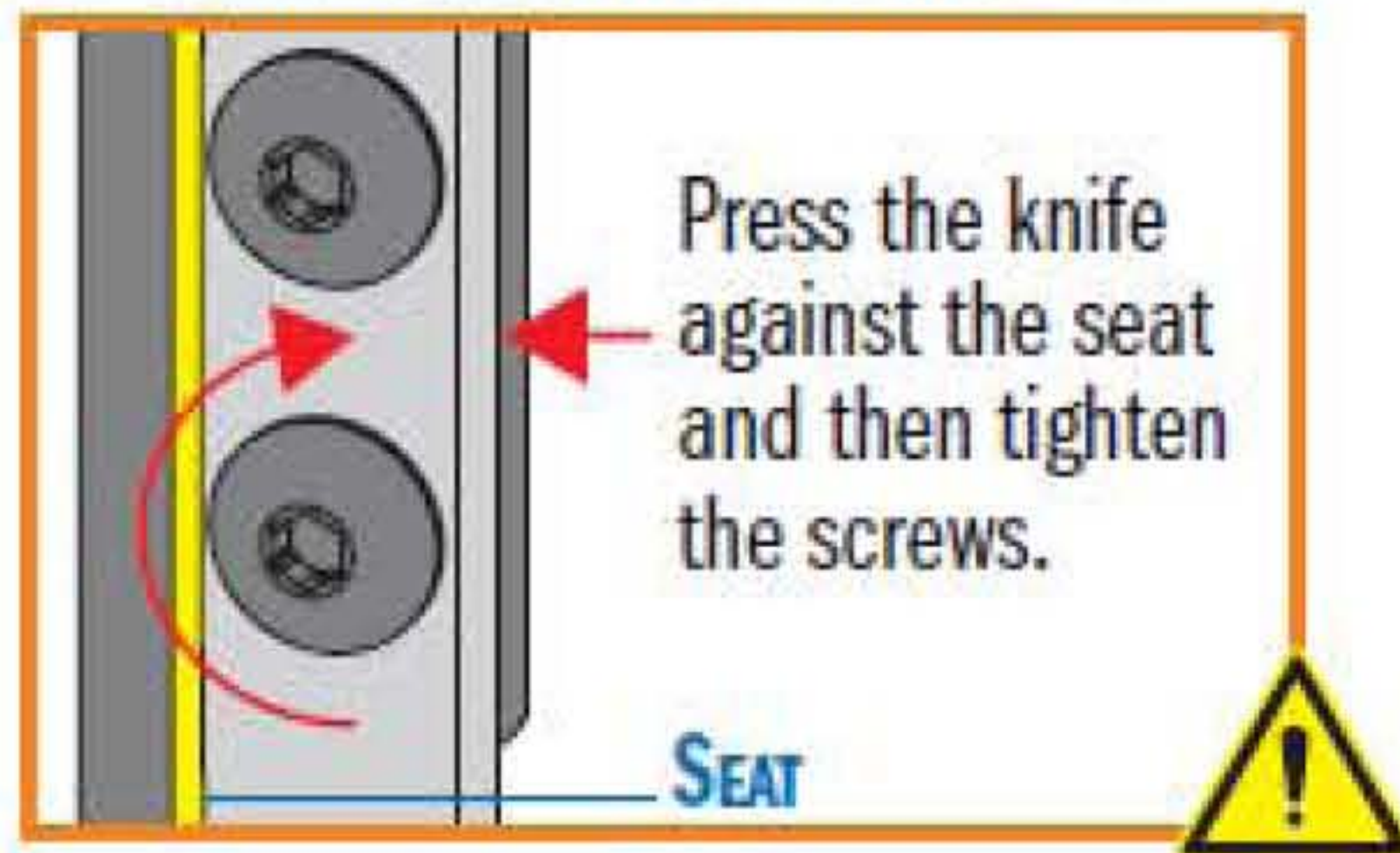

**TECHNICAL DETAILS:**

- Super Strength steel
- 1 cutting edges [Z1]

**APPLICATION:**  
 this innovative CNC router bit offers you an endless range of possibilities for V-Groove, miter folds, signmaking, lettering and chamfer edges. The tool mounts a high grade HWM reversible knife ideal for general purpose, chipboard and plywood, but a higher quality is available for laminated and MDF material.