

TEETH: 4
 HOOK: 15°
 SHEAR: 20°
 TIPS: INSERT
 PA: N/A

MAX RPM: 7,000
 MULTI-TASKER CUTTER #4-01-4792001
 INSERT #4-10-4792004
 BACKER #5-10-4792005

DWG: 4-01-4792000

PROFILE #: N/A

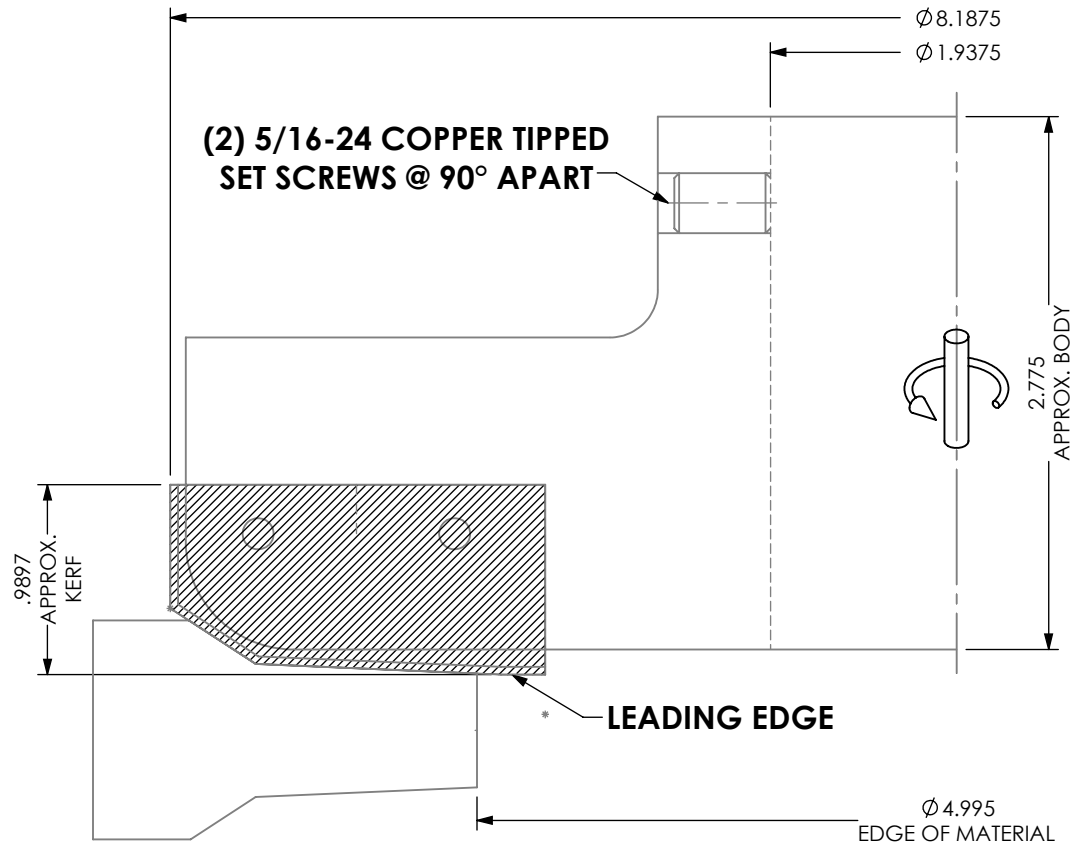
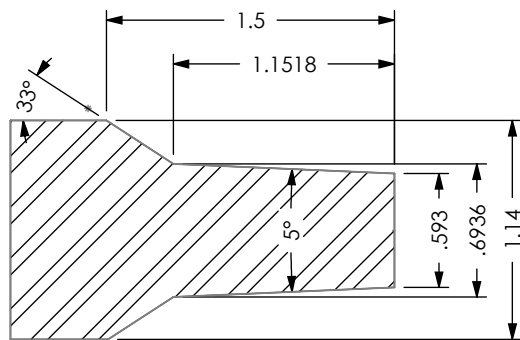

ATTN: _____ DATE: _____ PO#: _____

CUSTOM TOOLING MUST HAVE CUSTOMER APPROVAL PRIOR TO THE START OF MANUFACTURING. PLEASE REVIEW THIS DRAWING FOR ACCURACY, INCLUDING ROTATION, AND FAX A SIGNED AND DATED COPY. PRODUCTION WILL BEGIN UPON RECEIPT OF APPROVED DRAWING.

APPROVED BY: _____ DATE: _____

HALL MANUFACTURING DWG: 4-01-4792000

DATE:
6/22/20

DWN BY:
R.A.Y.



REV.
+

SHEET 2 OF 4