

TEETH: 3 EFF.  
 HOOK: 10°  
 SHEAR: 0°  
 TIPS: INSERT  
 PA: N/A

MAX RPM: 14,000

DWG: 4-01-4793100

A.K.A. #: N/A

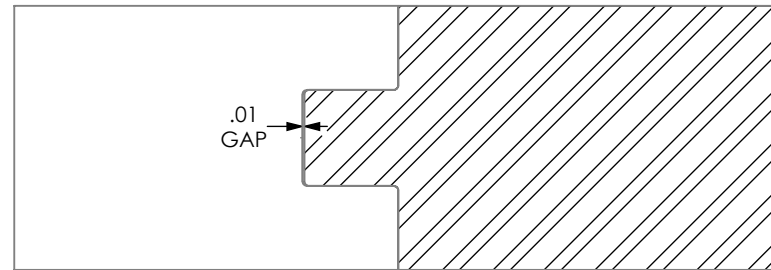
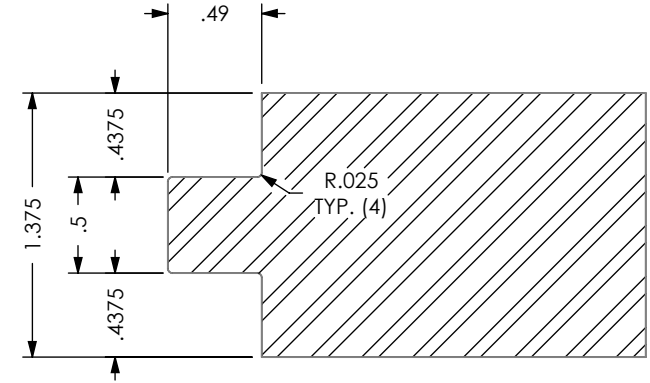
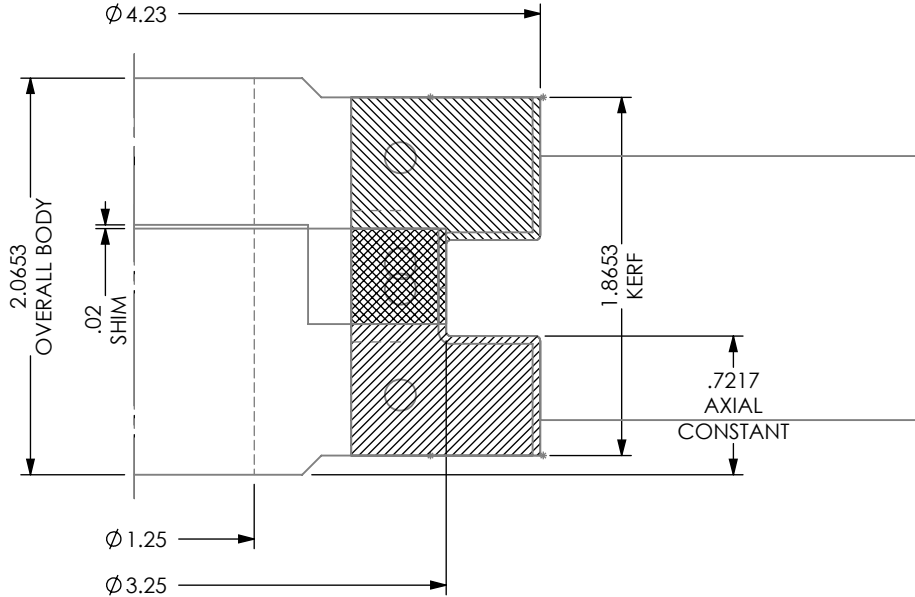
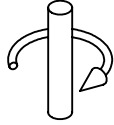

HALL MANUFACTURING DWG: 4-01-4793100

ATTN: \_\_\_\_\_ DATE: \_\_\_\_\_ PO#: \_\_\_\_\_

**CUSTOM TOOLING MUST HAVE CUSTOMER APPROVAL PRIOR TO THE START OF MANUFACTURING. PLEASE REVIEW THIS DRAWING FOR ACCURACY, INCLUDING ROTATION, AND FAX A SIGNED AND DATED COPY. PRODUCTION WILL BEGIN UPON RECEIPT OF APPROVED DRAWING.**

APPROVED BY: \_\_\_\_\_ DATE: \_\_\_\_\_

DATE:  
6/23/20

DWN BY:  
R.A.Y.



REV.  
+

SHEET 1 OF 6

TEETH: 3 EFF.  
 HOOK: 10°  
 SHEAR: 0°  
 TIPS: INSERT  
 PA: N/A

MAX RPM: 14,000

DWG: 4-01-4793100

A.K.A. #: N/A

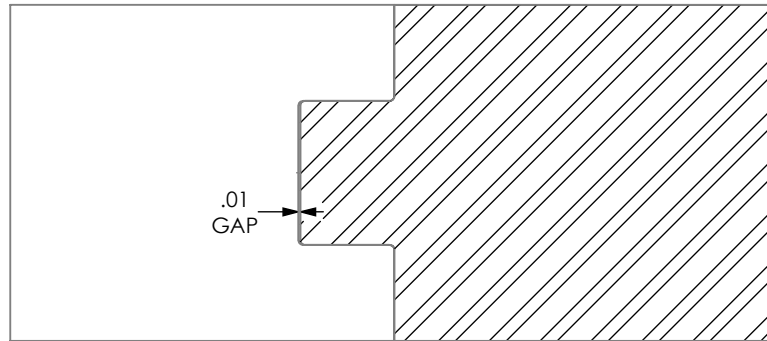
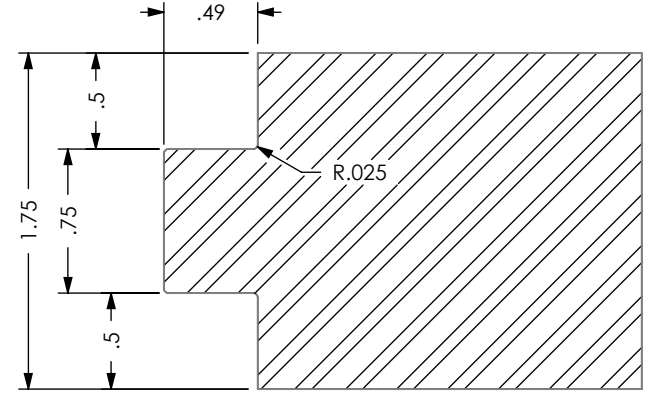
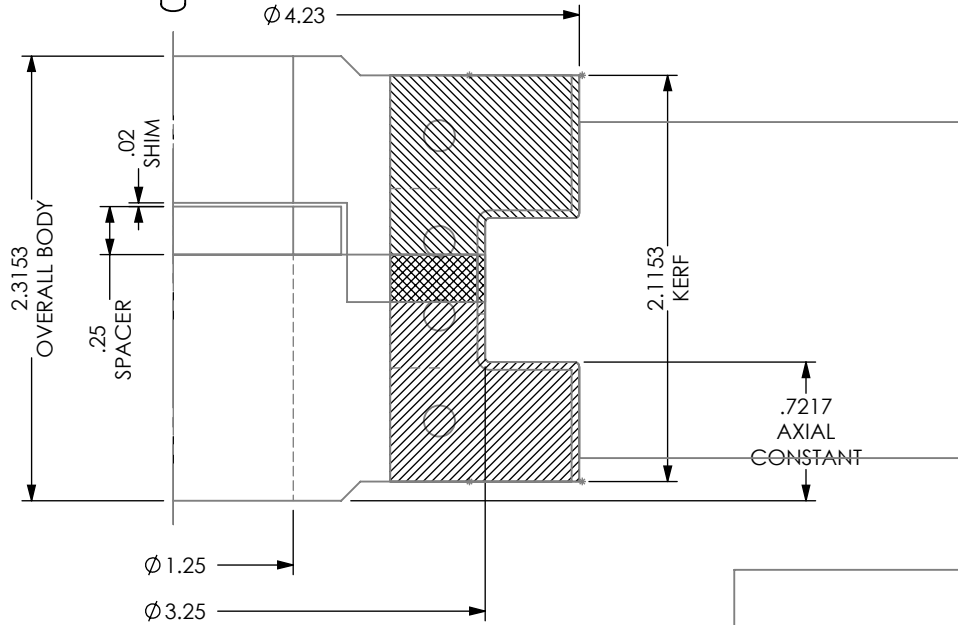
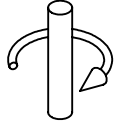

HALL MANUFACTURING DWG: 4-01-4793100

ATTN: \_\_\_\_\_ DATE: \_\_\_\_\_ PO#: \_\_\_\_\_

CUSTOM TOOLING MUST HAVE CUSTOMER APPROVAL PRIOR TO THE START OF MANUFACTURING. PLEASE REVIEW THIS DRAWING FOR ACCURACY, INCLUDING ROTATION, AND FAX A SIGNED AND DATED COPY. PRODUCTION WILL BEGIN UPON RECEIPT OF APPROVED DRAWING.

APPROVED BY: \_\_\_\_\_ DATE: \_\_\_\_\_

DATE:  
6/23/20

DWN BY:  
R.A.Y.

REV.  
+

SHEET 2 OF 6

