

TEETH: 3 EFF.
 HOOK: 5°
 SHEAR: 44°
 TIPS: PCD
 PA: 75.0mm

MAX RPM: 23,000

DWG: 1-03-4744000

PROFILE #: E19/E2

PROFILED SHANK ROUTER: #1-03-4744001
STRAIGHT CUTTER: #1-02-4746000

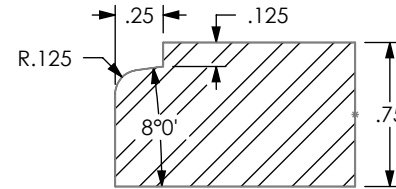
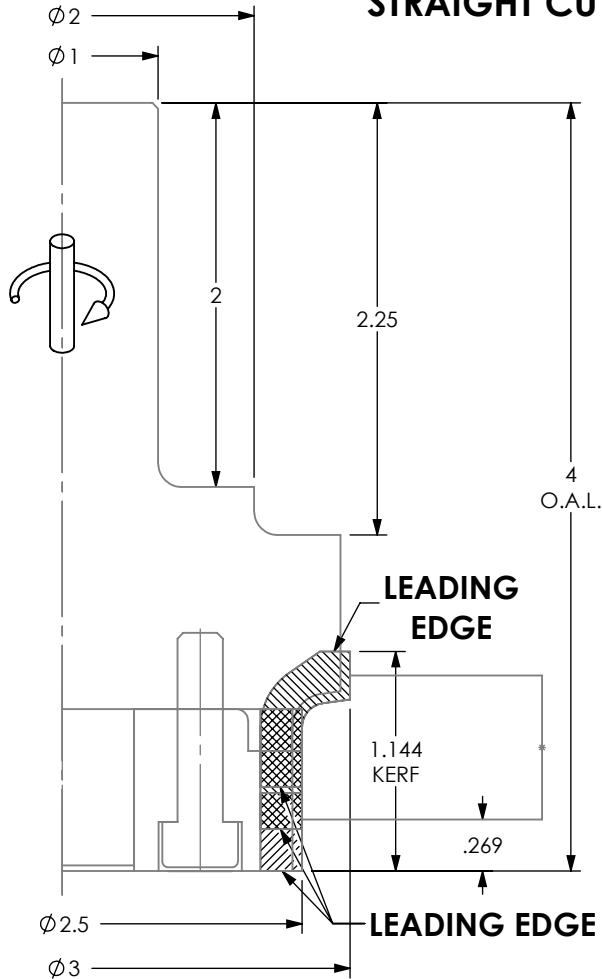

HALL MANUFACTURING DWG: 1-03-4744000

ATTN: _____ DATE: _____ PO#: _____

CUSTOM TOOLING MUST HAVE CUSTOMER APPROVAL PRIOR TO THE START OF MANUFACTURING. PLEASE REVIEW THIS DRAWING FOR ACCURACY, INCLUDING ROTATION, AND FAX A SIGNED AND DATED COPY. PRODUCTION WILL BEGIN UPON RECEIPT OF APPROVED DRAWING.

APPROVED BY: _____ DATE: _____

DATE:
5/13/20

DWN BY:
E.L.M.



REV.
02

SHEET 1 OF 5