

TEETH: 3 EFF.
 HOOK: 2°
 SHEAR: 30°
 TIPS: PCD
 PA: 101.25mm

MAX RPM: 17,000

DWG: 1-02-4929800

A.K.A. #: N/A

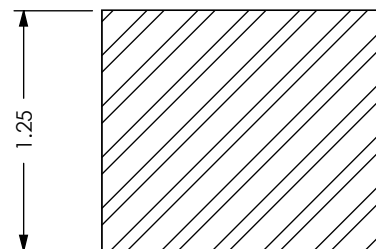
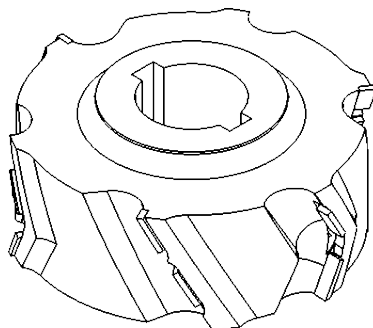
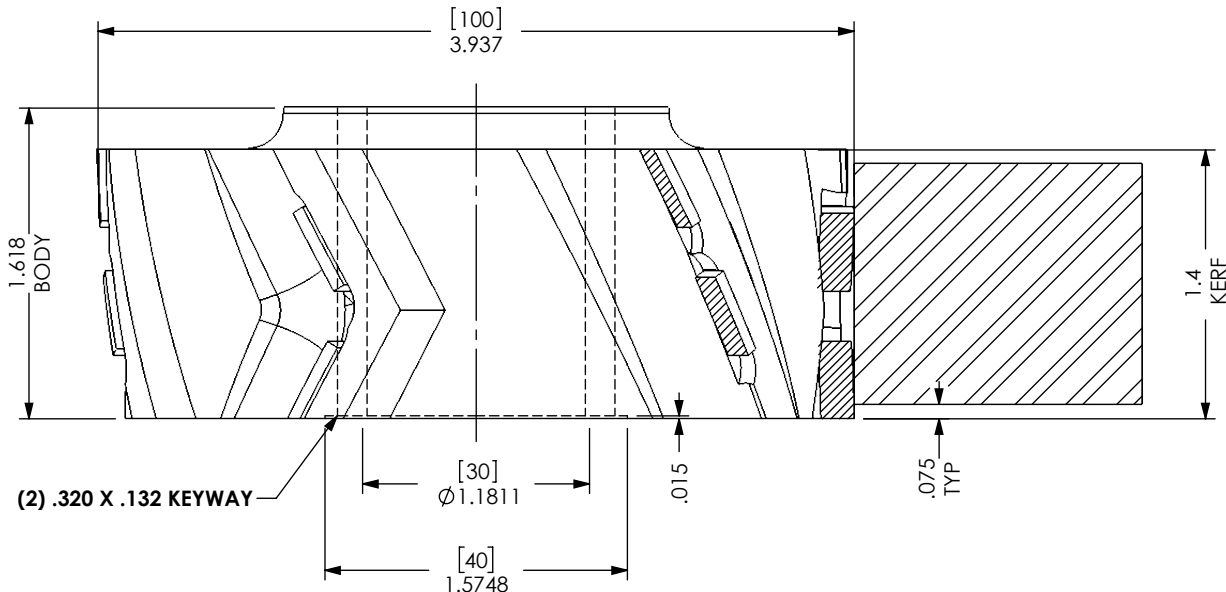

HALL MANUFACTURING DWG: 1-02-4929800

ATTN: _____ DATE: _____ PO#: _____

CUSTOM TOOLING MUST HAVE CUSTOMER APPROVAL PRIOR TO THE START OF MANUFACTURING. PLEASE REVIEW THIS DRAWING FOR ACCURACY, INCLUDING ROTATION, AND FAX A SIGNED AND DATED COPY. PRODUCTION WILL BEGIN UPON RECEIPT OF APPROVED DRAWING.

APPROVED BY: _____ DATE: _____

DATE:
12/22/20

DWN BY:
R.A.Y.



REV.
+

SHEET 1 OF 2