

TEETH: 3  
 HOOK: 10°  
 SHEAR: 0°  
 TIPS: INSERT  
 PA: N/A

MAX RPM: 13,000  
 CUTTER HEAD: #4-01-4518800  
 INSERT: #4-10-4518803  
 BACKER: #5-10-4518804

DWG: 4-01-4518800

PROFILE #: McLEOD

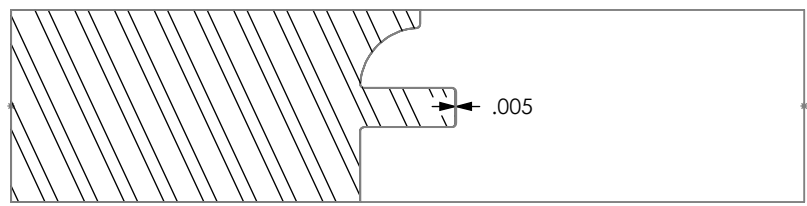
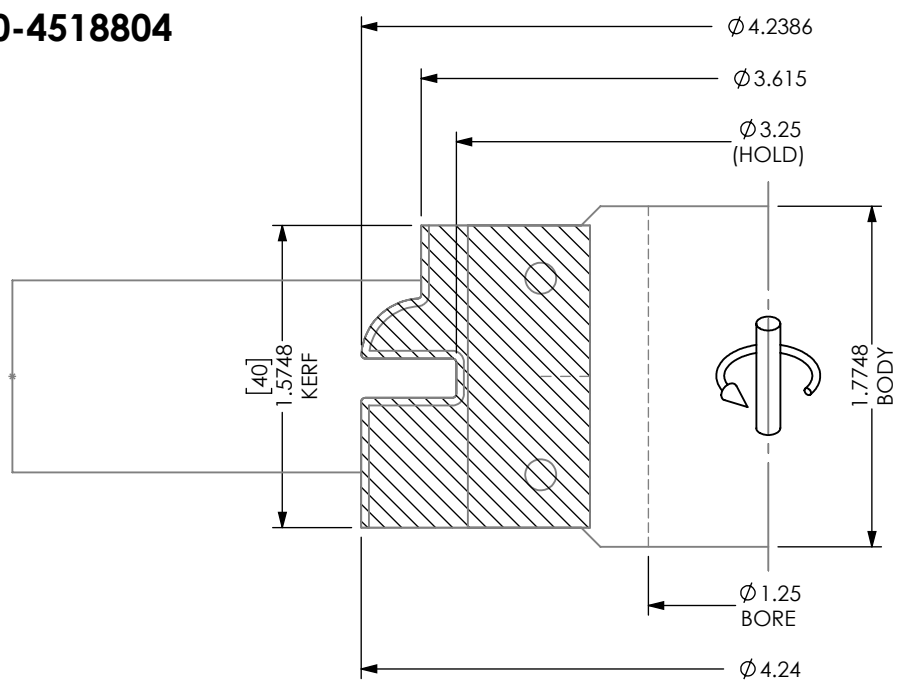
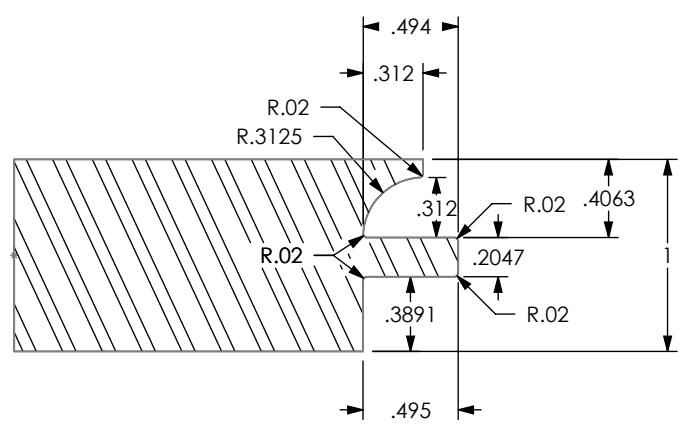

HALL MANUFACTURING DWG: 4-01-4518800

ATTN: \_\_\_\_\_ DATE: \_\_\_\_\_ PO#: \_\_\_\_\_

CUSTOM TOOLING MUST HAVE CUSTOMER APPROVAL PRIOR TO THE START OF MANUFACTURING. PLEASE REVIEW THIS DRAWING FOR ACCURACY, INCLUDING ROTATION, AND FAX A SIGNED AND DATED COPY. PRODUCTION WILL BEGIN UPON RECEIPT OF APPROVED DRAWING.

APPROVED BY: \_\_\_\_\_ DATE: \_\_\_\_\_

DATE:  
12/19/19

DWN BY:  
RWB



REV.  
+ SHEET 2 OF 4