

TEETH: 3
 HOOK: 10°
 SHEAR: 0°
 TIPS: INSERT
 PA: N/A

MAX RPM: 13,000

DWG: 4-01-4518700

CUTTER HEAD: #4-01-4518700

PROFILE #: McLEOD

INSERT: #4-10-4518703

BACKER: #5-10-4518704

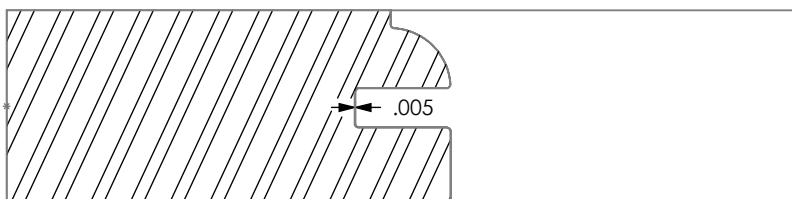
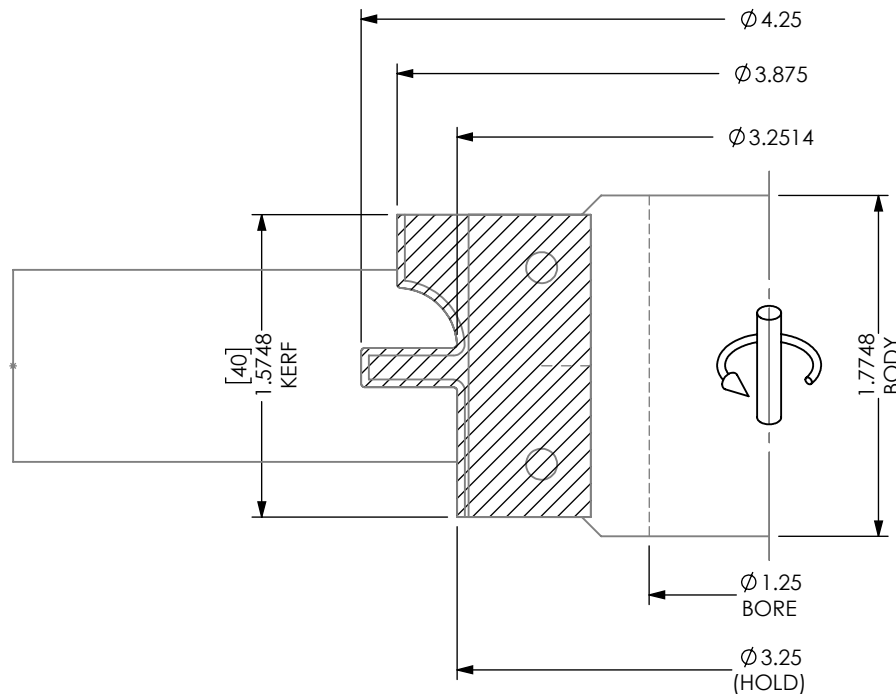
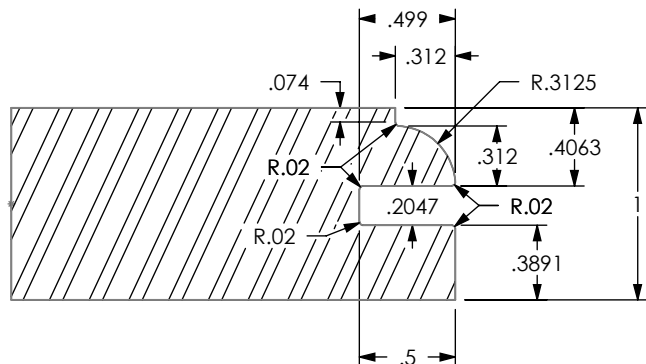

HALL MANUFACTURING DWG: 4-01-4518700

ATTN: _____ DATE: _____ PO#: _____

CUSTOM TOOLING MUST HAVE CUSTOMER APPROVAL PRIOR TO THE START OF MANUFACTURING. PLEASE REVIEW THIS DRAWING FOR ACCURACY, INCLUDING ROTATION, AND FAX A SIGNED AND DATED COPY. PRODUCTION WILL BEGIN UPON RECEIPT OF APPROVED DRAWING.

APPROVED BY: _____ DATE: _____

DATE:
12/19/19

DWN BY:
RWB



REV.
+ SHEET 2 OF 4