

TEETH: 3
HOOK: 10°
SHEAR: 0°
TIPS: CARBIDE
PA: N/A

MAX RPM: 14,000

DWG: 4-01-4189100

A.K.A. #: N/A

CUTTER BODY #4-01-4189100 INSERT #4-10-4189101

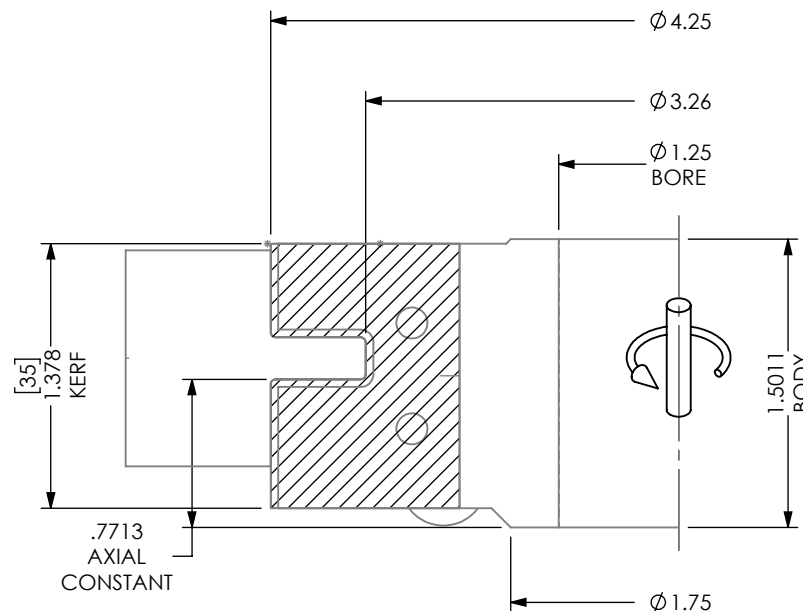
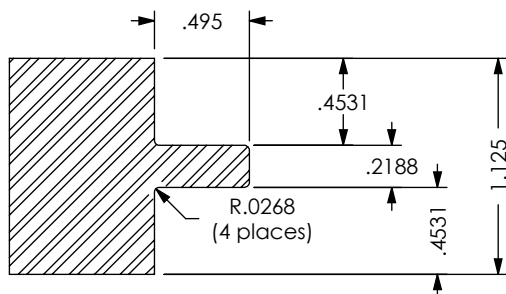

HALL MANUFACTURING DWG: 4-01-4189100

ATTN: _____ DATE: _____ PO#: _____

CUSTOM TOOLING MUST HAVE CUSTOMER APPROVAL PRIOR TO THE START OF MANUFACTURING. PLEASE REVIEW THIS DRAWING FOR ACCURACY, INCLUDING ROTATION, AND FAX A SIGNED AND DATED COPY. PRODUCTION WILL BEGIN UPON RECEIPT OF APPROVED DRAWING.

APPROVED BY: _____ DATE: _____

DATE:
7/5/18

DWN BY:
G.R.F.

REV.
+

SHEET 1 OF 5

