

992



KINETIC
DUST EXTRACTOR

ORDER NO.		inches	D mm	DESCRIPTION
992.081.ER20	1	3-5/32	80	Kinetic Dust Extractor for chucks with ER20 collets
992.081.ER25	1	3-5/32	80	Kinetic Dust Extractor for chucks with ER25 collets
992.101.EOC25	1	3-15/16	100	Kinetic Dust Extractor for chucks with DIN6388/EOC25 collets
992.101.ER32	1	3-15/16	100	Kinetic Dust Extractor for chucks with ER32 collets
992.101.ER40	1	3-15/16	100	Kinetic Dust Extractor for chucks with ER40 collets

Spare parts 991.285.00 C-Spanner 80-90mm (ER20/ER25)
991.284.00 C-Spanner 95-100mm (EOC25/ER32/ER40)



Always use with suction hose

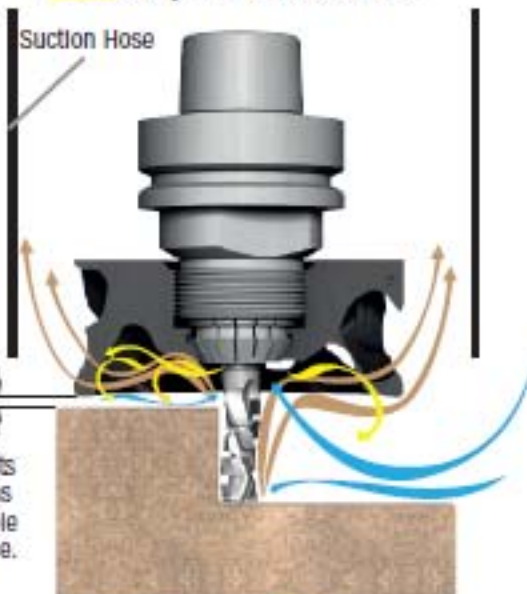

1/16" - 3/8"

For better results keep the tool as close as possible to the workpiece.

Compressed Air Dust Air Vacuumed

EASY TO USE!

Removes MDF & Chipboard dust from the workpiece
Install & remove as a clamping nut

- Health & Safety
- Tool Performance & Cut Quality
- Tool Life & Labor Costs
- Recommended for Nesting and Routing operations
- No wasted time during work process
- Replaces the standard clamping nut
- Suitable for any collet chucks with standard router bits
- Available for ER32 - ER40 - EOC25 (DIN6388) collets
- The thick ceramic coat gives KDE an anti-corrosion, anti-friction and anti-static surface.
- Tool body in light alloy
- Better air quality
- Good performances even at low rpm: from 6,000 up to 20,000 rpm
- Material: chipboard, coated chipboard, MDF, Corian®, plasterboard, OSB, HPL.



Download Instructions

Watch the video on

YouTube



Watch Video

Working **WITHOUT** Kinetic Dust Extractor



Working **WITH** Kinetic Dust Extractor

